



DIGITAL COLOR LABEL PRINTING

Flexibility at your finger tips



Eugene Villareiz

Business Development Manager

Epson Philippines Corporation



Label Printing

Flexibility at your finger tips

imagine it. realise it.



Why need industrial labeler?

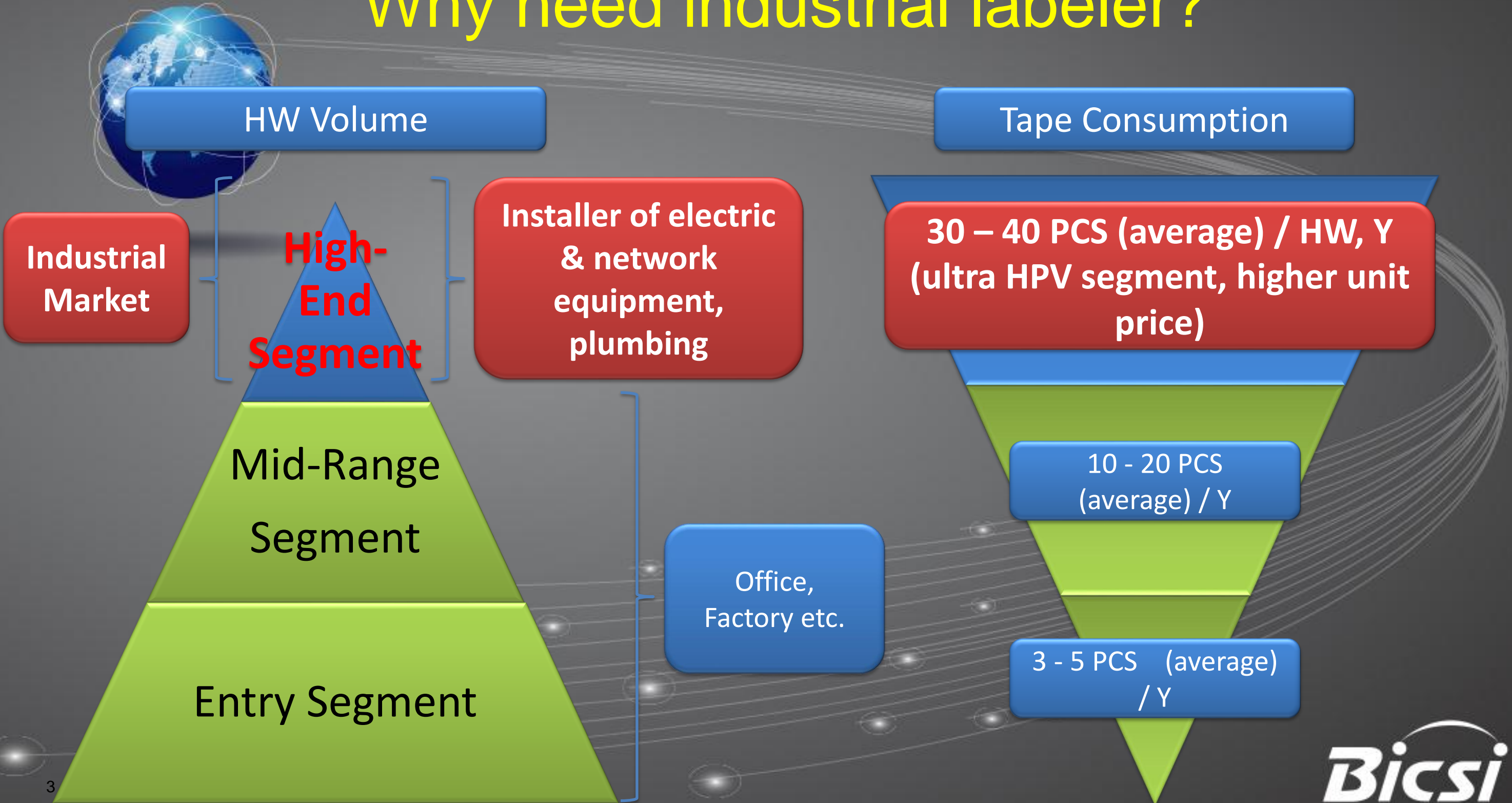



User

- Users who are considering the purchase of industrial labeler
 - Need labeler that can print up to **36mm width tapes at reasonable price**
 - Who have frustration with high tape running cost
 - Need **lower running cost of tape**
 - Need to use very special tapes or customized tapes



Office Building / Data Centre -

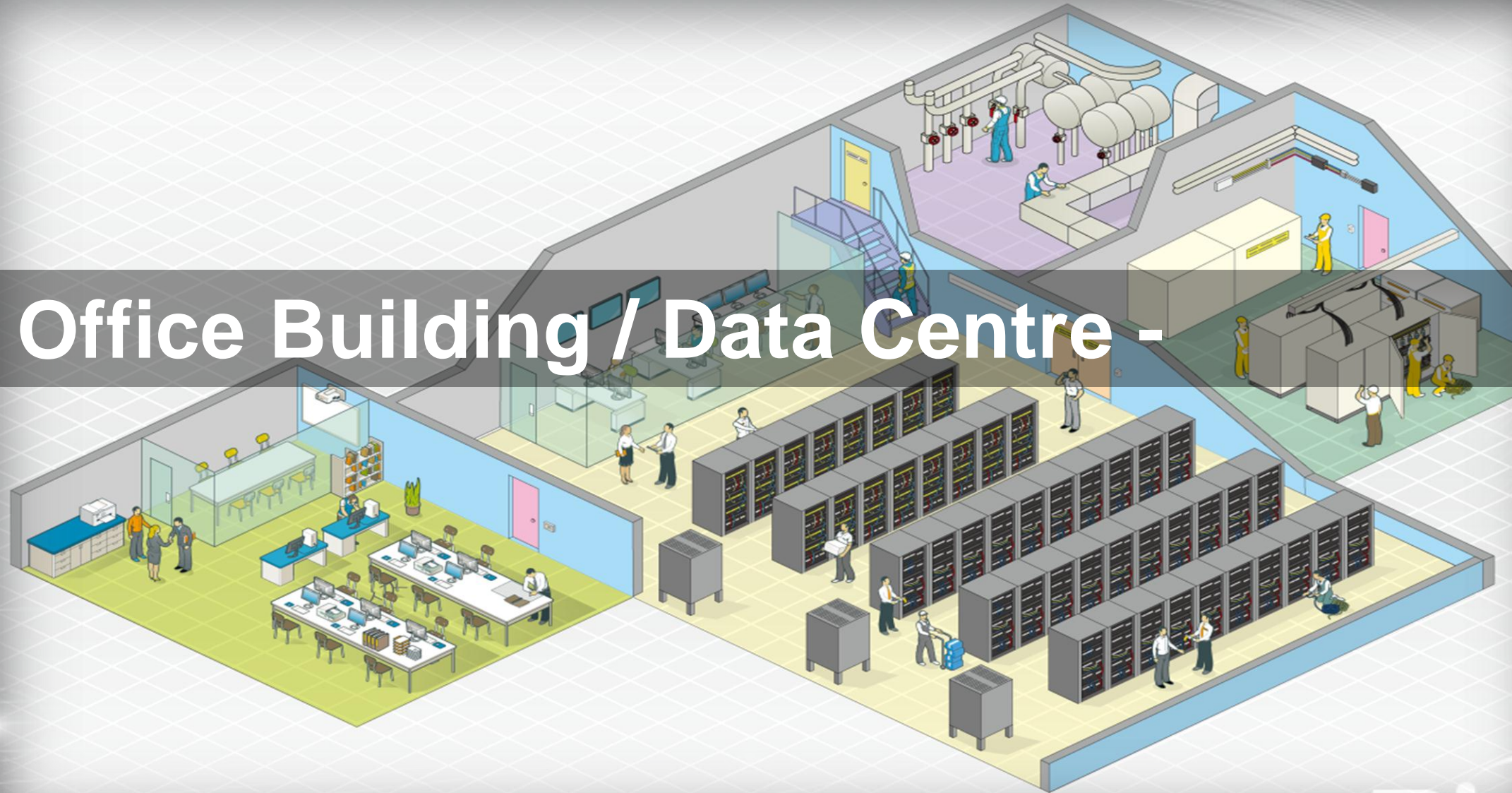



- Electric Power Control Room / Electric Power Distribution Board





- Server Room / Network Equipment

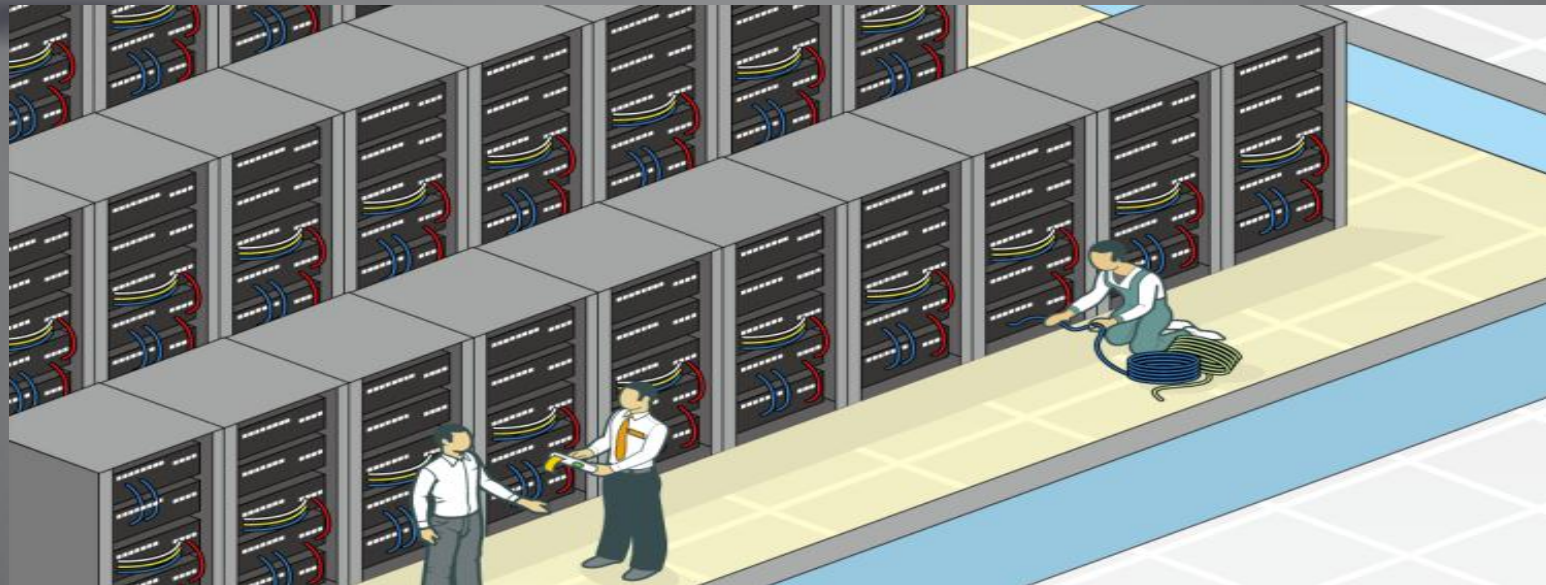



- Air-Conditioning System / Water Control System / Gas Control System

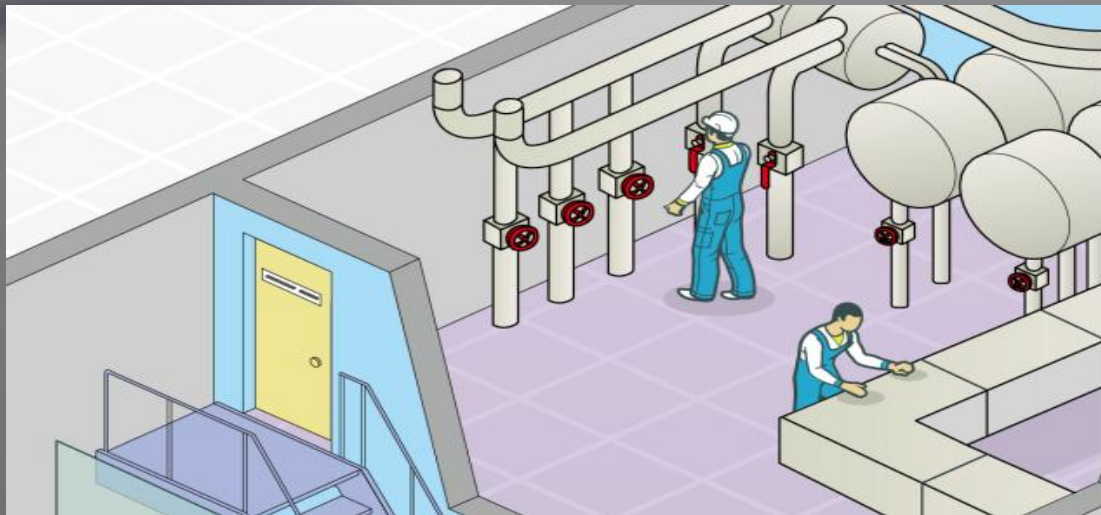



Manufacturing

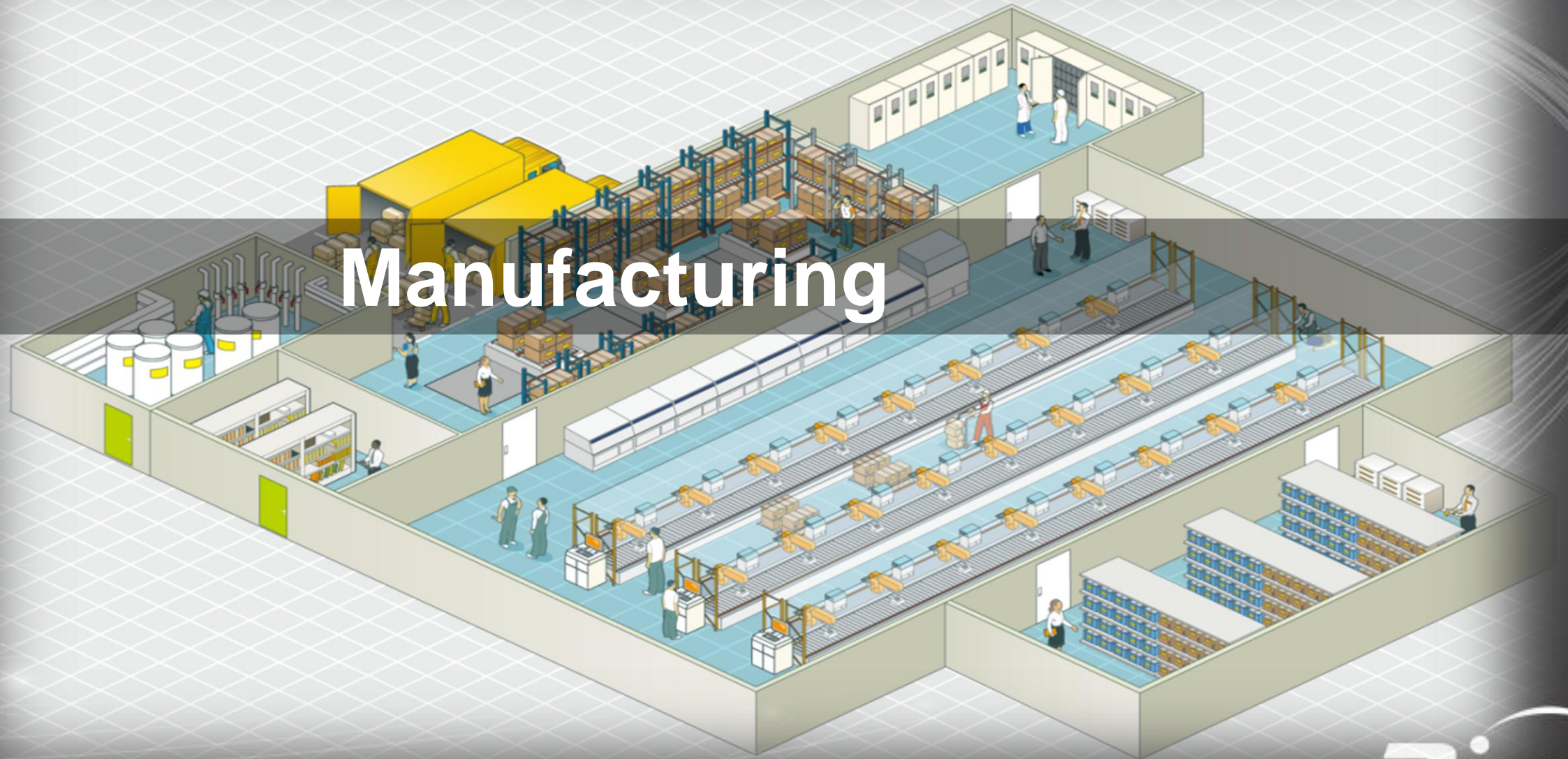



- Electric Power Control Room / Electric Power Distribution Board

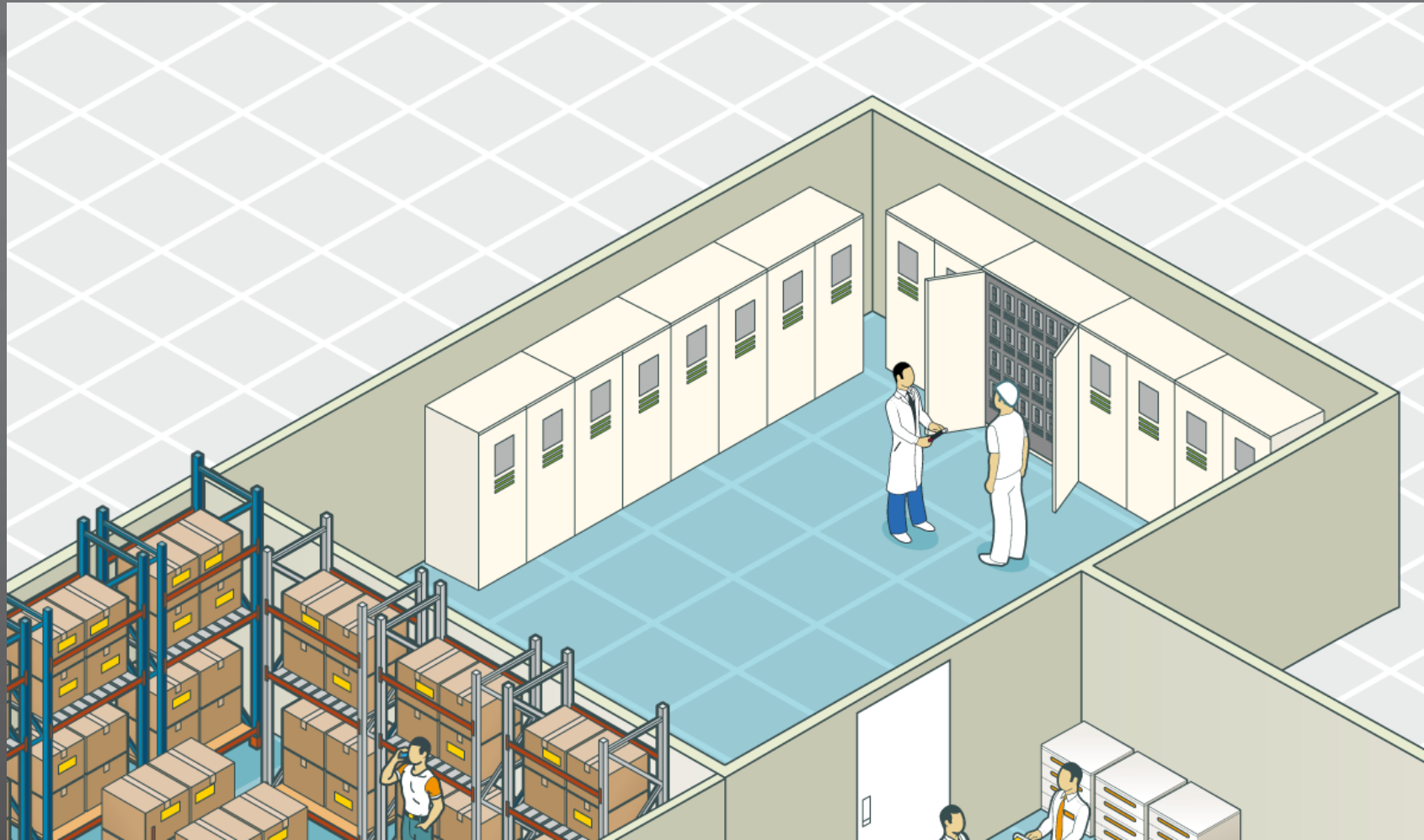



- Server Room / Network Equipment

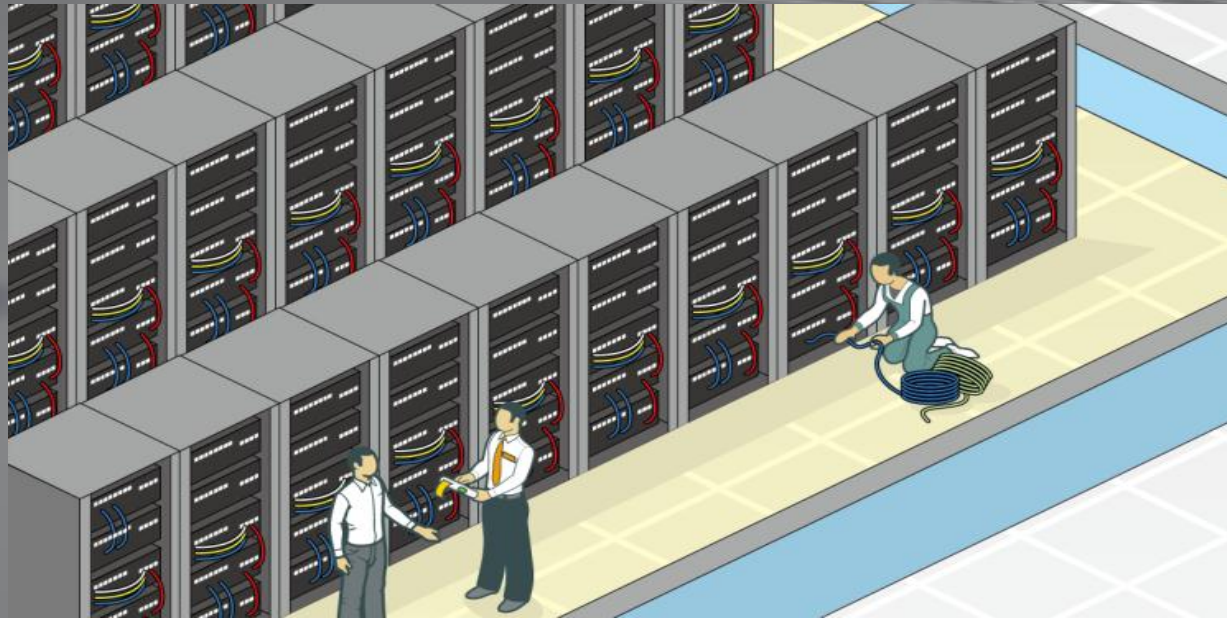



- Air-Conditioning System / Water Control System / Gas Control System

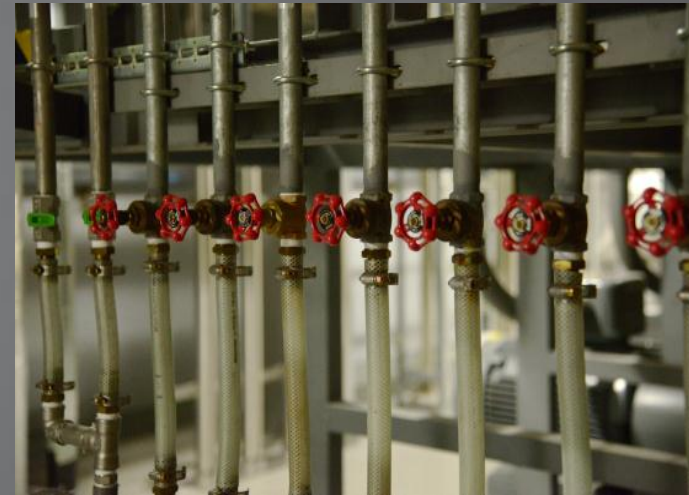
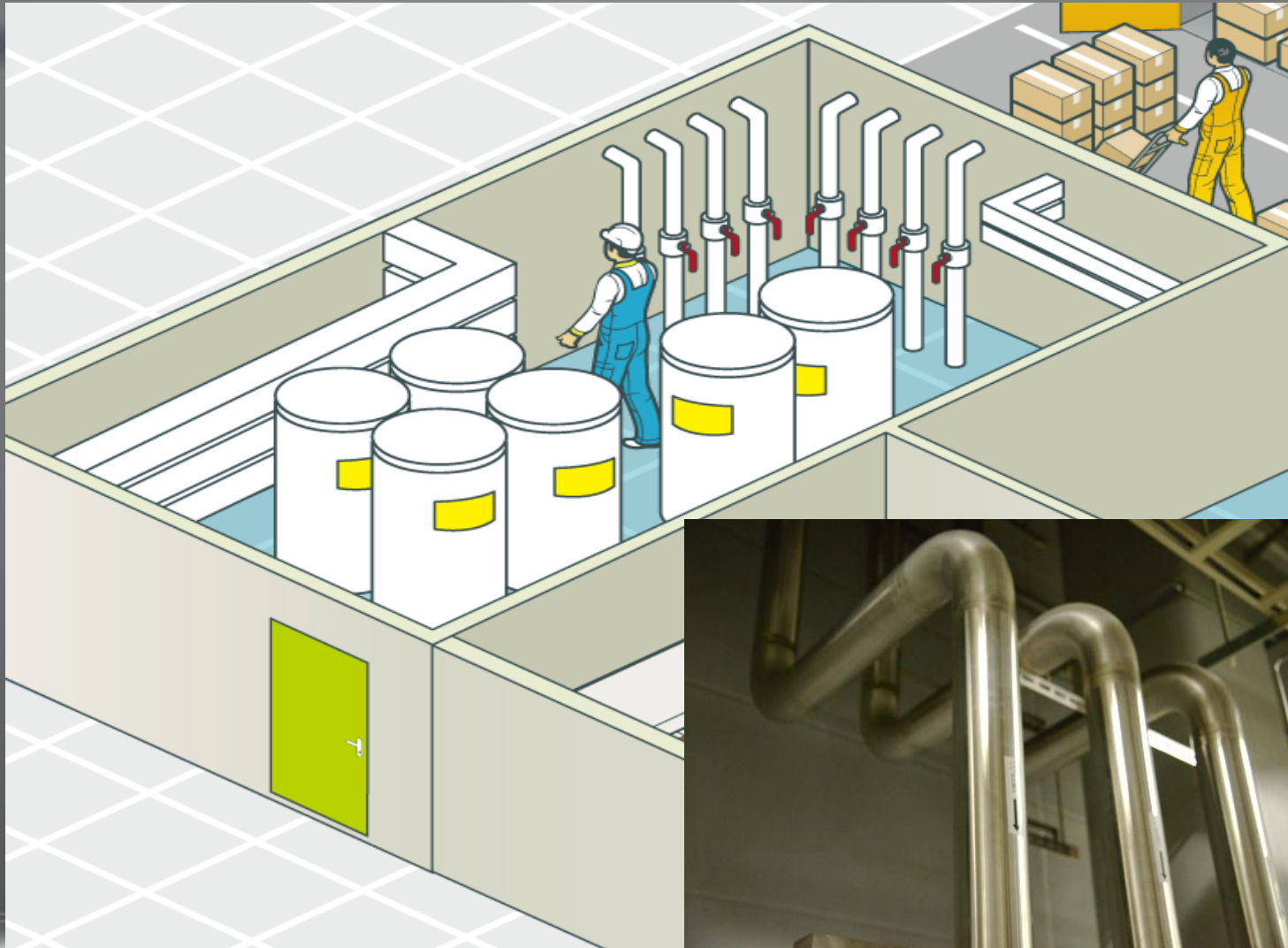



- FA (Factory Automation) Equipment / FA Controller

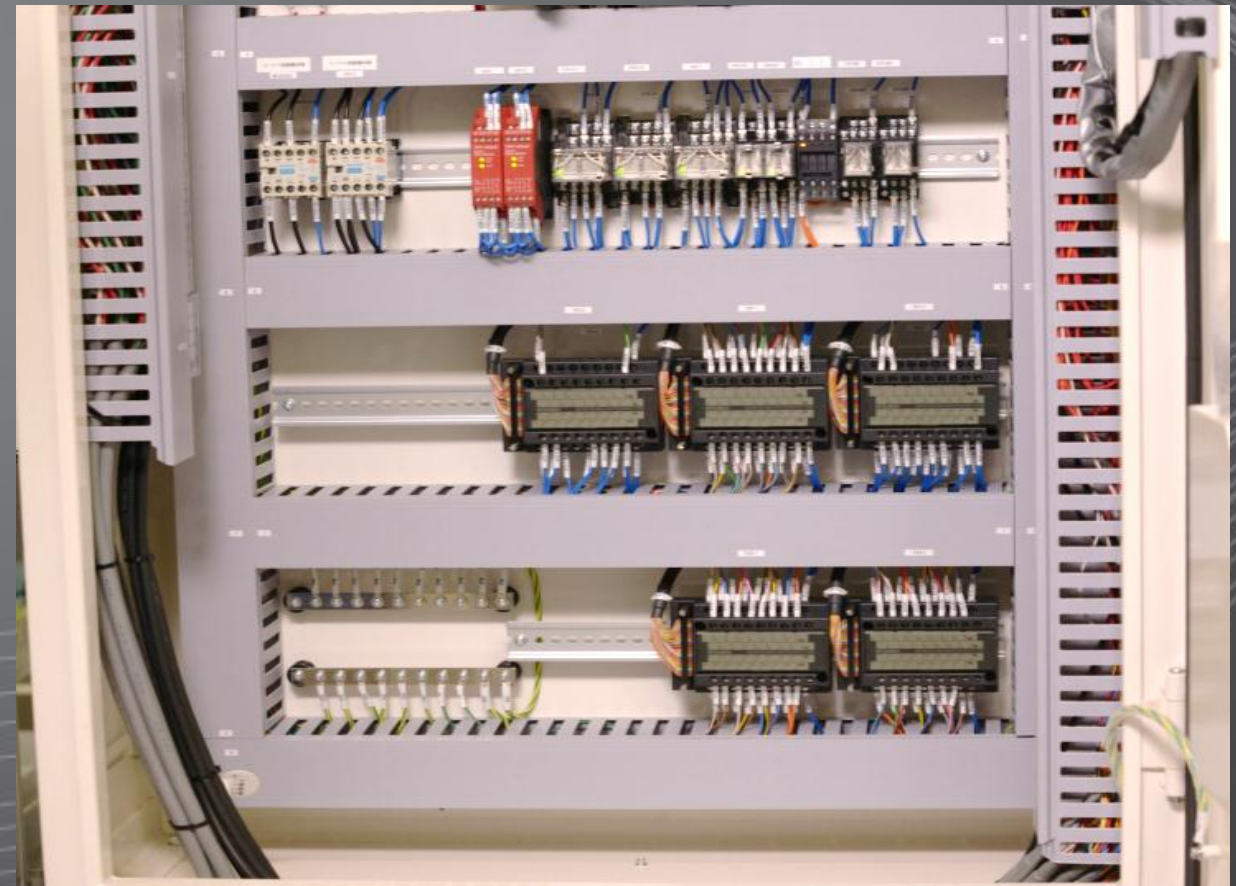
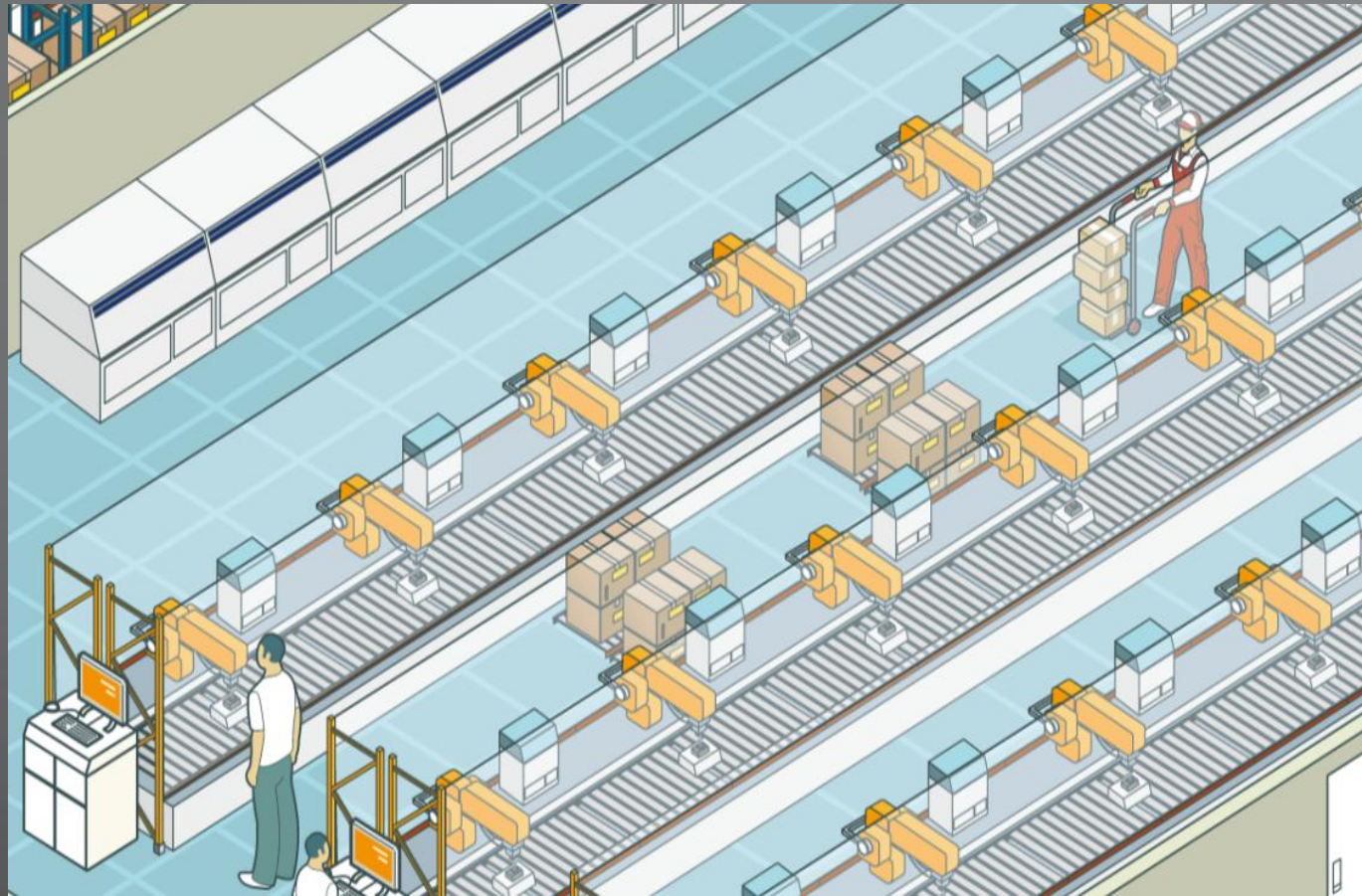



To Save Cost



To save cost: Tape Rewinding & 9M Tape

- Rewind tape before starting printing
 - Shorten the front margin from approx. 10mm to approx. 4mm
 - Limitation
 - ✓ Tape rewind function doesn't work for the following tapes
 - HST
 - Self-lamination Overwrap (Cable Wrap)
 - Ribbon
 - GID
 - Reflective
 - Heat- resistance
 - Magnet
 - iron



To save cost: Tape Rewinding & 9M Tape

Much lower TCO by "Tape Rewinding" function and 9M tape

1 Digit Label
(Tape Length Auto)

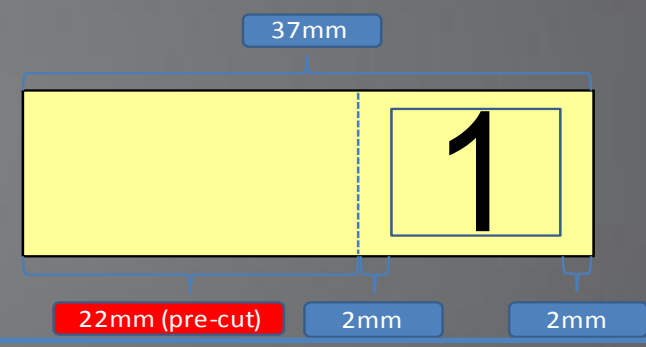
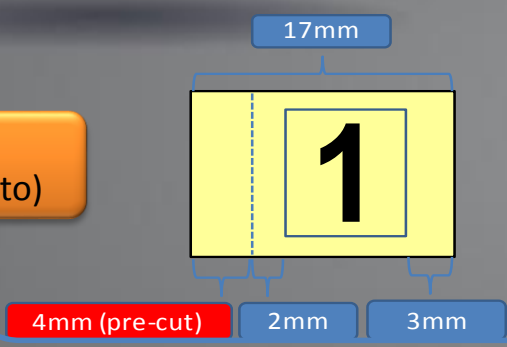

5 Digit Label
(Tape Length Auto)

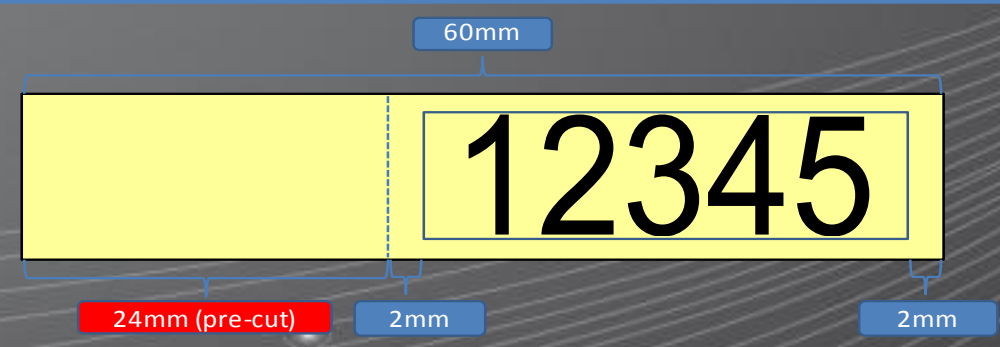
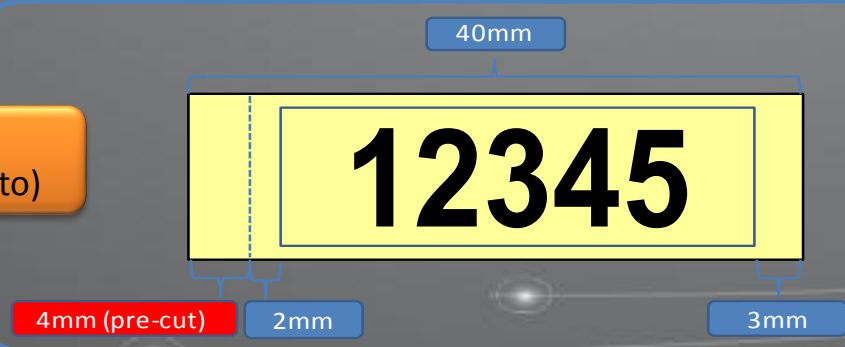

10 Digit Label
(Tape Length Auto)

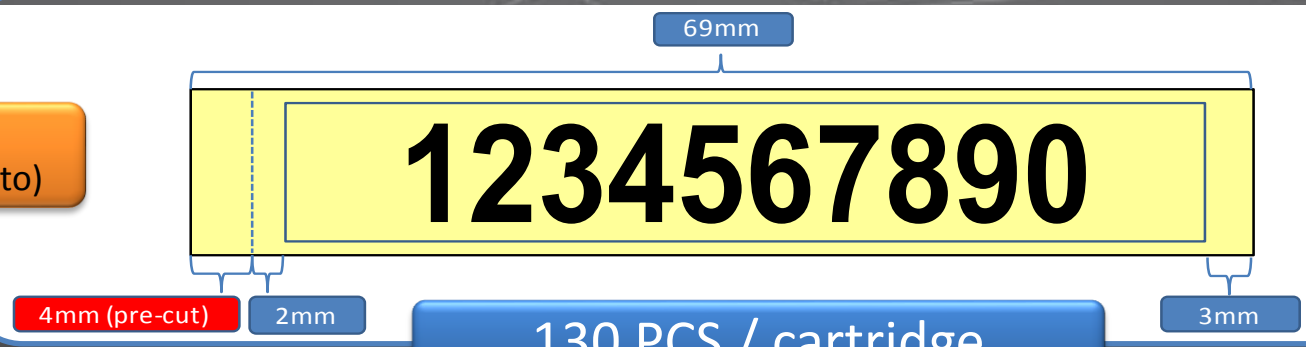

130 PCS / cartridge

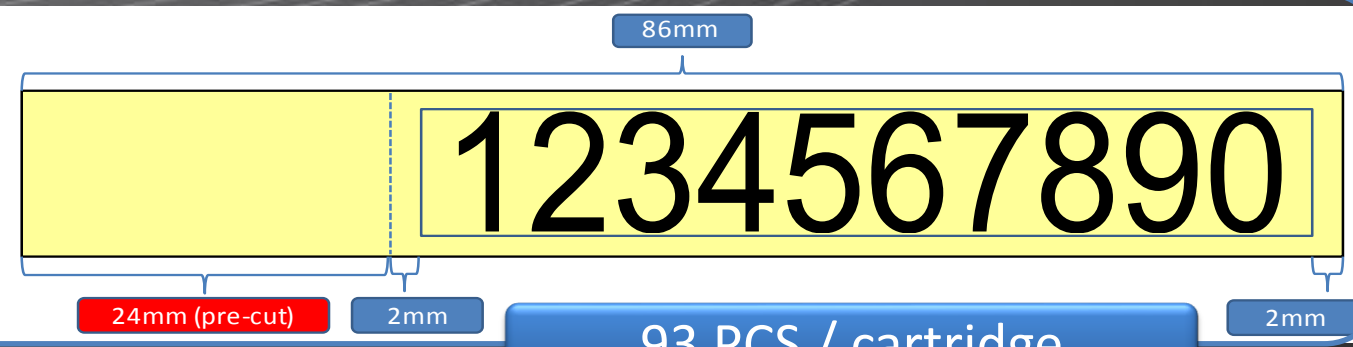

93 PCS / cartridge



To save cost: Higher impact resistance

- Comply with Mil Spec.
 - Need to pass the impact test dropped from 1.22m height
 - Evaluation method
- Not easy to be damaged by several impact



To Save Time



To save time: A wide variety of tape width can be used (4-36mm)

Possible to use a wide variety of tape width

Tape width: 4mm – 36mm

4mm	Photo Data
6mm	November 14, 2013
9mm	For internal use only
12mm	Let's Recycle!
18mm	Switch off when not in use
24mm	Asset No. Asset name Date : 11/1 Dept. : Pla
36mm	CAUTION



To save time: Easy to create label

- Shorten the input time by “Hot Key”

P.Block (Punch Block)

Start count	1	4	8	12	16	20	24
Second count	25	28	32	36	40	44	48

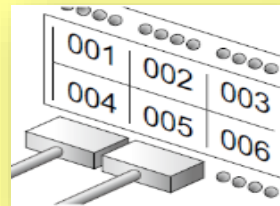

Block-66

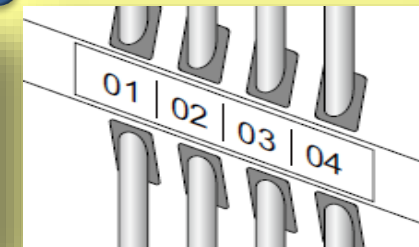
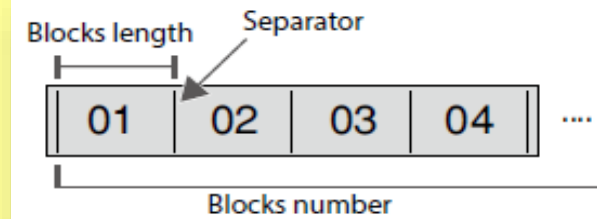

P.Panel (Patch Panel)

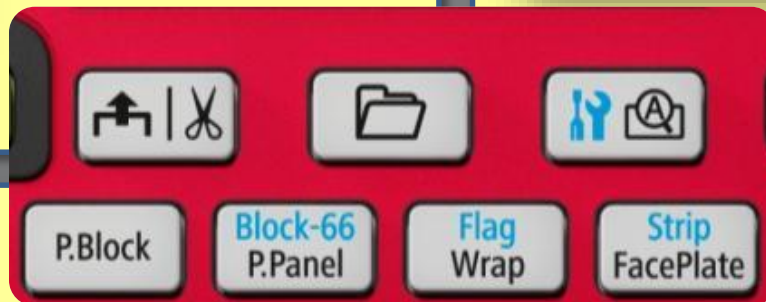
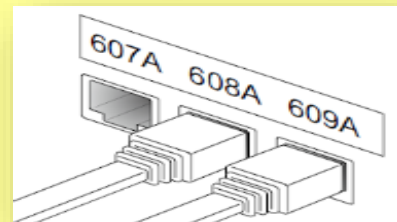
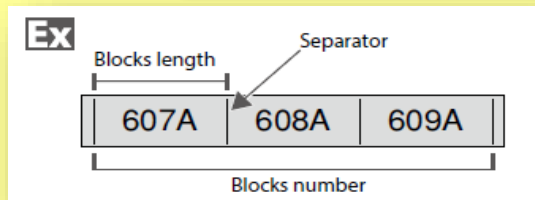

MIX-Len

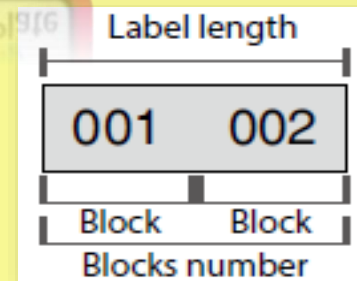

Face Plate

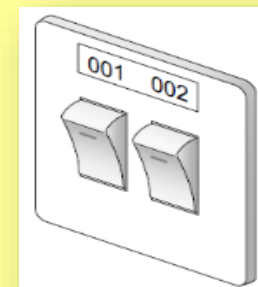



To save time: Easy to create label

➤ Shorten the input time by “Hot Key”

Wrap

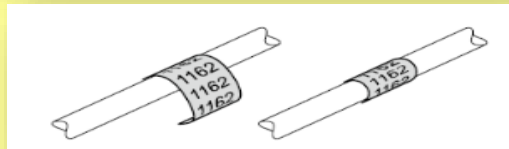
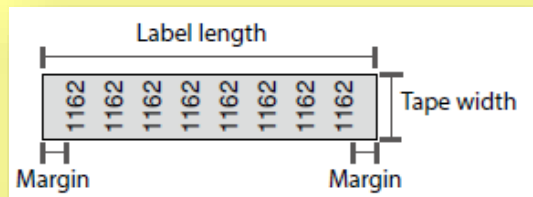

Flag

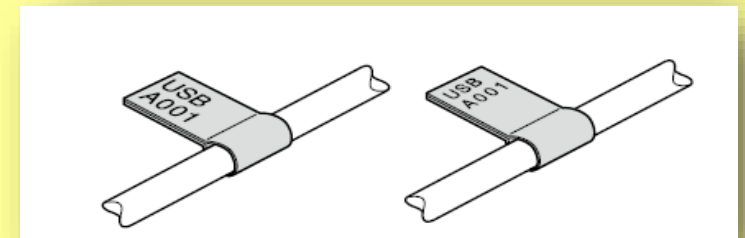
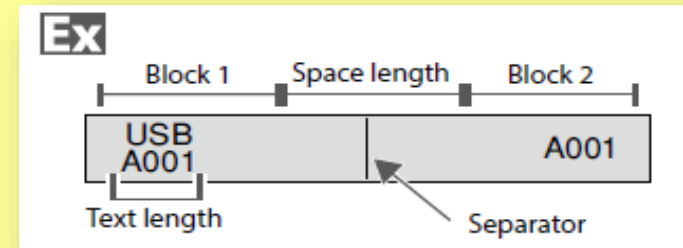

Mix-Len (Mix Length)

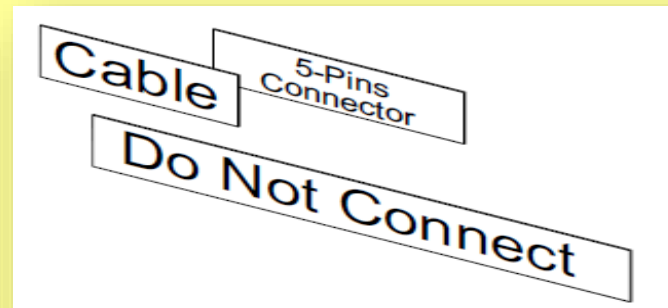
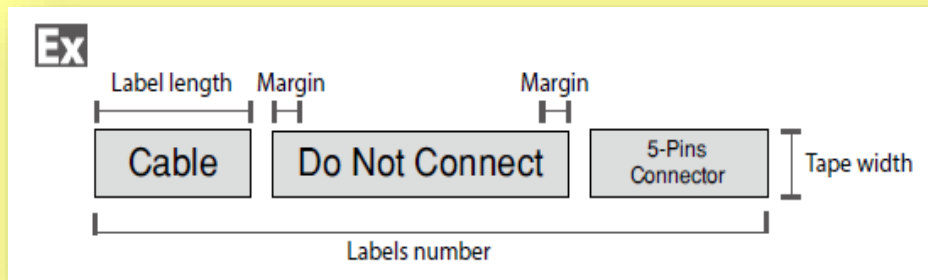



To save time: Easy to create label

Mix Length

Max. 50 different length of labels can be printed

Mix-Len
(Mix Length)

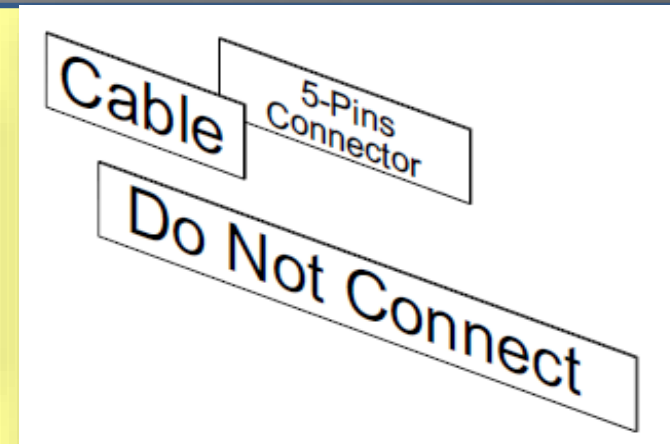
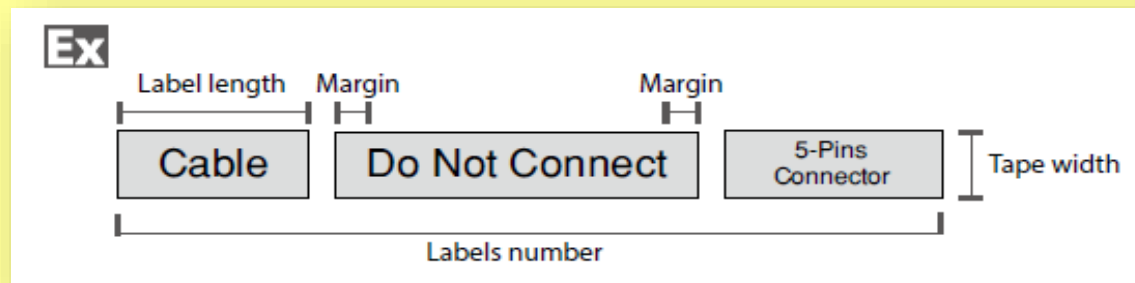

- Total number of label pattern which can be saved
- 100 pattern of label can be saved



To save time: Easy to create label

- Useful printing and cutting method to support labeling in every field

Printing Mode	Cutting Mode	New Function	Remarks
Single Label Printing	Auto cut or Half cut	Drop stop	Drop stop function works when label length is 28mm or more
Multiple Label Printing	Auto cut	Pick & Print 	Drop stop function works when label length is 28mm or more
Multiple Label Printing	Half cut	Half cut 	Drop stop function works when label length is 28mm or more



To save time: Data Download & PC Connection

- Data download function
 - Possible to download and save label data which was created by Label Editor on PC
 - Print label created by PC
- PC connection
 - Possible to print label created by Label Editor by connection to PC





Conventional vs. Digital Color Label Printing

imagine it. realise it.

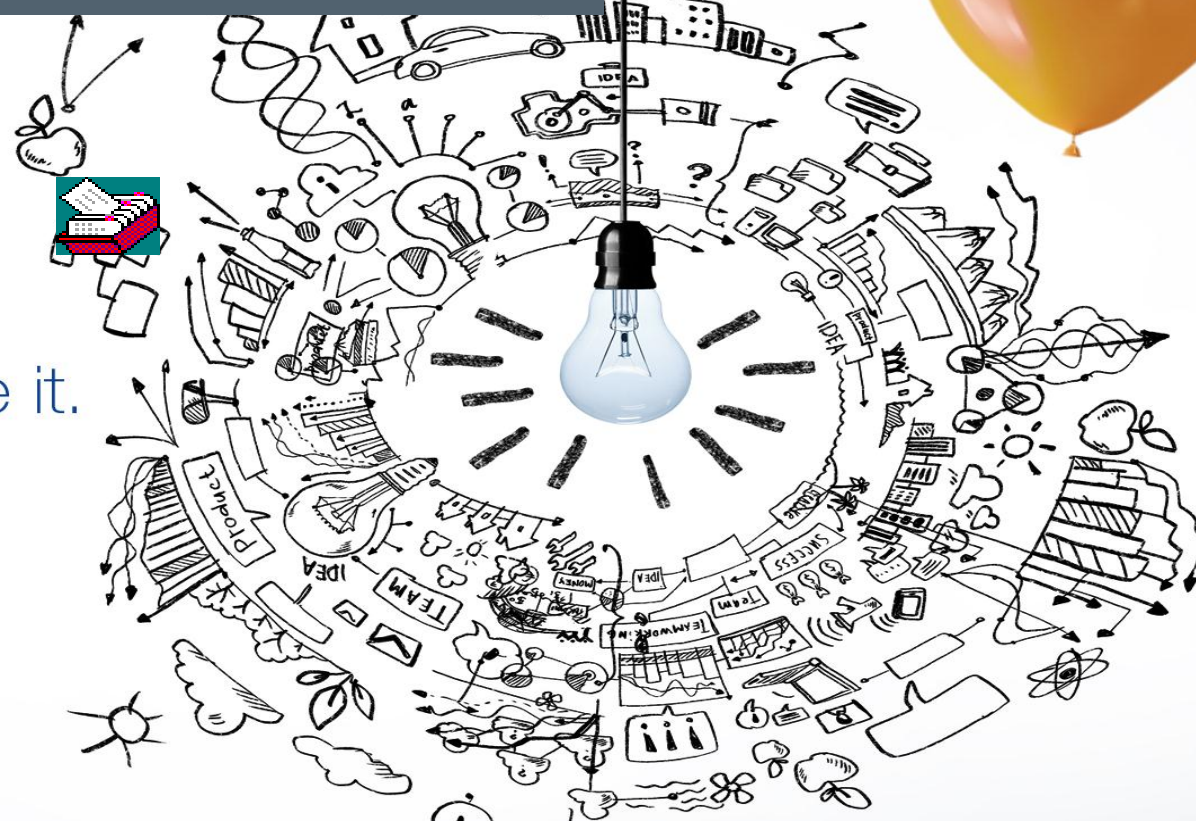

THE PACKAGING & PRIME LABELS DOMAIN



LABELS **90%**

FOLDING CARTONS

5%

FLEXIBLE PACKAGING

5%



LABEL PRINTING METHODS



Offset **21%**

Flexo **65%**

Screen
Gravure
Letterpress
Digital Press **14%**

- Digital Press** will grow due to :
- Increase in Low Volume Job
 - Variable Data Printing
 - Speed & Flexibility
 - Cost control
 - Private Labels
 - Test Marketing



Digital Color Label Printing is an enhancement, not a replacement of Conventional Label Printing practices

THE LABEL DOMAIN



PRIME LABELS

Packaging Labels



Labels put on a product at time of manufacture to promote and sell a product



TRACE & TRACK LABELS



GHS Labels



HEALTHCARE & WARNING LABELS

SECONDARY LABELS



DIGITAL COLOUR LABEL PRINTING

Short Run, On Demand Color Label Printing – The Paradigm Shift



PACKAGING & LABELS IN MANUFACTURING



PRODUCE



PRIMARY LABELLING

AGGLOMERATION



DISTRIBUTION



SECONDARY LABELLING

WHAT HAPPENS WHEN THERE IS A SHORT RUN JOB REQUIREMENT?

CONVENTIONAL 2-STEP APPROACH

- Pre-printed labels
- Print the barcode



- Create the plate (CTP)
- Print the labels



DIGITAL 1-STEP APPROACH

- Create the design in PC
- Print the labels on demand



Bicsi

SECONDARY LABELS



GROWTH IN COLOUR REQUIREMENT

HEALTHCARE



PACKAGING & REPACKAGING



FOOD & NUTRITION

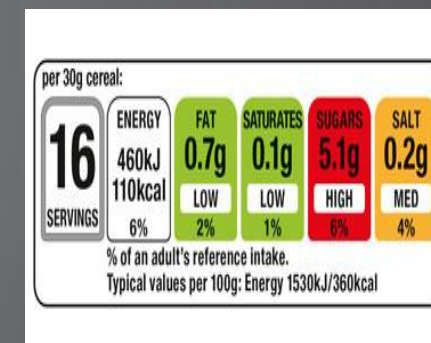

Nutrition Facts	
Serving Size 1 cup (228g) Servings Per Container 2	
Amount Per Serving	
Calories 260	Calories from Fat 110
% Daily Value*	
Total Fat 12g	18%
Saturated Fat 3g	15%
Trans Fat 3g	
Cholesterol 30mg	10%
Sodium 470mg	20%
Potassium 700mg	20%
Total Carbohydrate 31g	10%
Dietary Fiber 6g	0%
Sugars 5g	
Protein 5g	
Vitamin A	4%
Vitamin C	2%
Calcium	20%
Iron	4%

*Percent Daily Values are based on a diet of other people's misdeeds.
Your Daily Values may be higher or lower depending on your calorie needs.

	Calories 2,000	2,500
Total Fat	Less than 65g	80g
Sat Fat	Less than 20g	25g
Cholesterol	Less than 300mg	300mg
Sodium	Less than 2,400mg	2,400mg
Total Carbohydrate	300g	375g
Dietary Fiber	25g	30g

US Department of Health has set out how food labels will look like and outlined how a colour-coding scheme of energy, salt, sugar and fat will look and how their levels are set.

DIGITAL COLOR LABEL ON-DEMAND PRINT ADVANTAGE

- COST SAVINGS** -Low Volume, Short Run jobs
- FLEXIBILITY** -Variable Data, High Mix SKUs
- CONTROL** -In House On Demand Printing





DIGITAL COLOUR LABEL PRINTING

Digital Color Label Solution

DIGITAL LABEL PRINTING SOLUTION



INDUSTRIAL



COMMERCIAL



PERSONAL



COMMERCIAL
Print Svc Providers

IN-HOUSE PRINTING

Manufacturing, Pharmaceutical, Healthcare,
HVAC, Construction, Industrial, Logistics, etc

Home & Small Office

WIDE

EXCELLENT

WIDE

MEDIA VERSITILITY

PRINT QUALTY

LABEL WIDTH

LIMITED

MODERATE

NARROW

Prime Labels



Secondary Labels

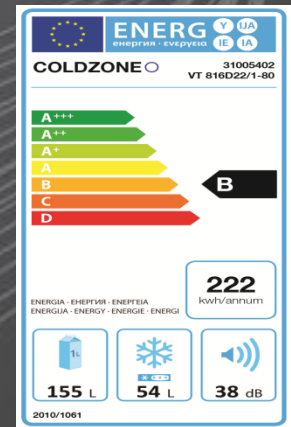
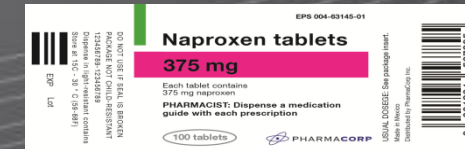



THANK YOU