



Technical Planning for Moving Into a Colocation Data Center



Jonathan Jew

J&M Consultants, Inc.

Co-chair BICSI Data Center Subcommittee
Secretary TIA TR-42 Telecommunications Cabling
Systems

Chair TIA TR-42.6 Telecom Administration
Vice-chair TIA TR-42.3 Pathways & Spaces
Vice-chair US-TAG to ISO/IEC JTC 1 SC 25 WG 3

www.j-and-m.com





Moving to a Colo?

- Colocation facility (colo) allows outsourcing of many data center functions allowing faster deployment, reducing initial capital costs, and permitting Information Technology (IT) to concentrate on IT rather than facility issues
- Careful planning and investigation are needed before committing to move into a Colo
- Ensure that the Colo facility meets your requirements
- Ensure that you and the Colo fully understand your requirements in detail



1. Administrative

1. Site code name (helps when communicating with the colo to use the same name for the site that they do)
2. Primary contact for addressing technical questions and issues
3. Site address, floor, & room name, & cage #/code for deliveries and work requests





2. Floor plan

1. Obtain floor plan of the room showing proposed suite/cage
2. Does equipment fit in the space with desired cabinets and adjacencies including door(s), ramp(s) if needed, aisles, columns, and other support equipment required to be in the space (electrical, cooling, fire suppression)
3. Is there room for expansion? If so, where?
4. Any adjacent rooms that could be of concern (electrical rooms or elevators that could create EMI), competitors whom I don't want to be able to view equipment in my cage?





2. Floor plan

- Fit equipment in with desired adjacencies
- Consider space and location of door(s), ramp(s), aisles, columns, electrical distribution, air conditioning equipment
- Will it all fit?
- Is there room to grow?
- Do I need space for other needs such as media storage or support staff?

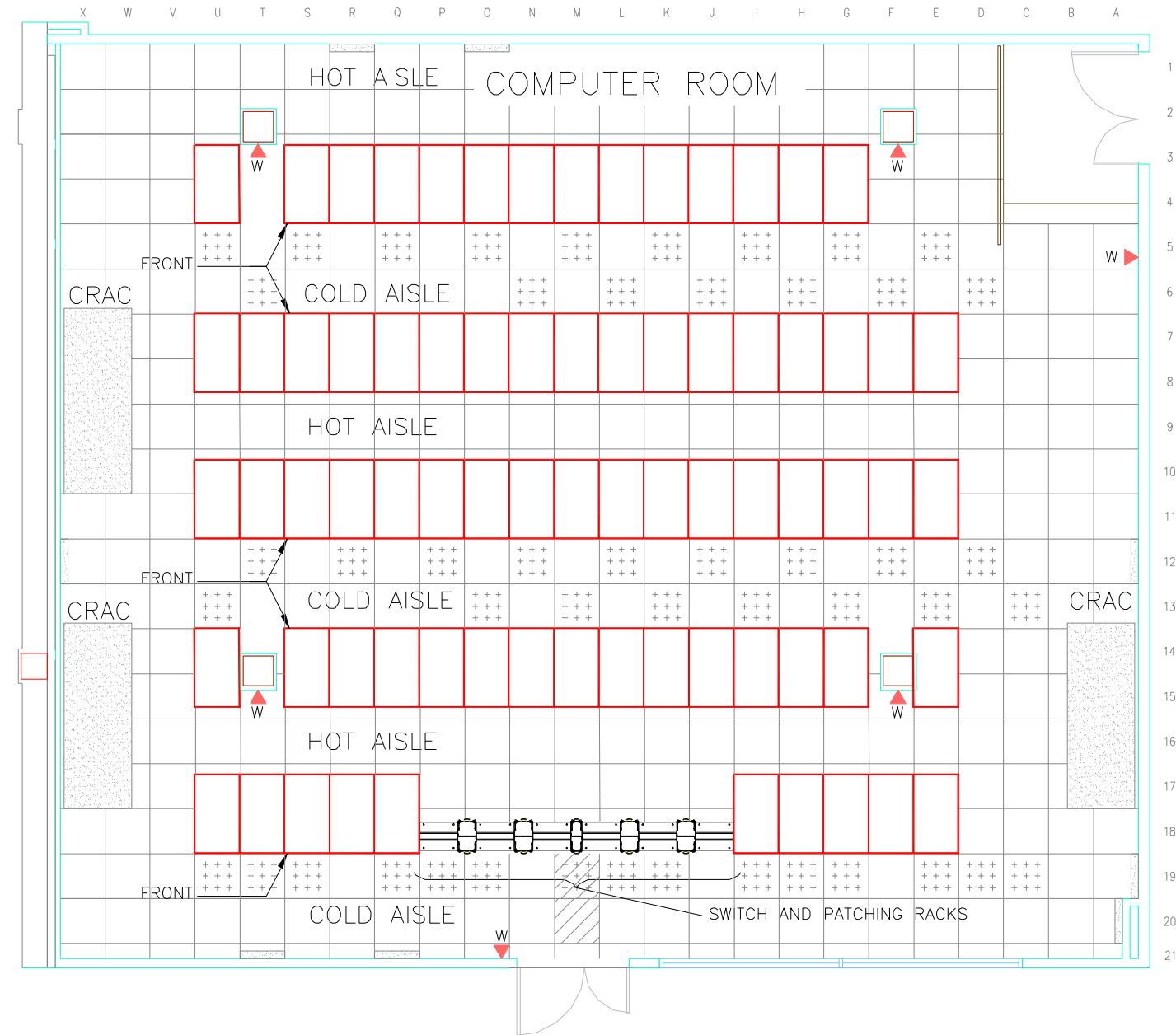



3. Clear Ceiling Height

1. What height do I require for the cabinets/racks including overhead cable tray and optical fiber duct?
2. What is the ceiling height?
3. What is the minimum height of obstructions such as lights, sprinklers, beams, etc.?
4. Where are the sprinkler heads (can they be moved)?
5. What clearance do local codes require around the sprinkler (for example, in the US it is a 450 mm/18" dome around the sprinkler head)?
6. Where are the light fixtures? They should be above the aisles and not above the cabinets/trays to meet 500 lux requirement in aisles
7. What are the height of the loading dock door, elevators, and all doors along the route from the loading dock to the cage/suite? Is it tall enough for the tallest cabinet on a pallet?





Clear Ceiling Height

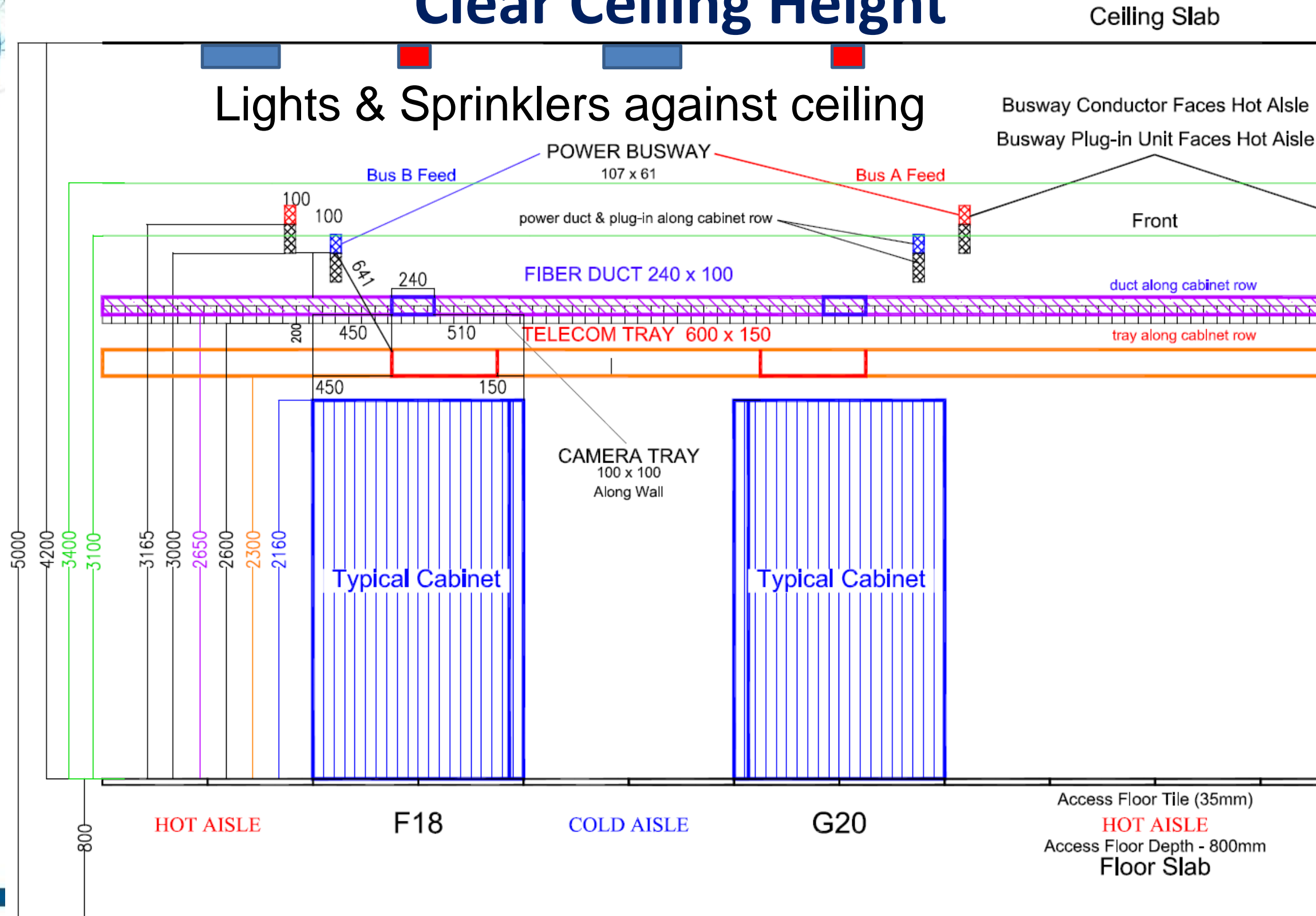



4. Floor Load ratings

1. Estimate the weight of the heaviest cabinets when fully loaded with expected equipment
2. What are the weight and dimensions of the heaviest cabinets anticipated (e.g., storage array cabinet can be 1,200 kg)?
3. What are the static, dynamic, and concentrated load specifications of the floor (per engineer and access floor system manufacturer)?
4. What are the seismic risks and requirements for this site? Should we use seismic cabinets?
5. What is the construction of the floor slab – are we permitted to bolt the cabinets to the slab? If not, what measures does the colo propose/permit for adequately securing the cabinets?





Example of Seismic Bracing where colo doesn't permit drilling into slab

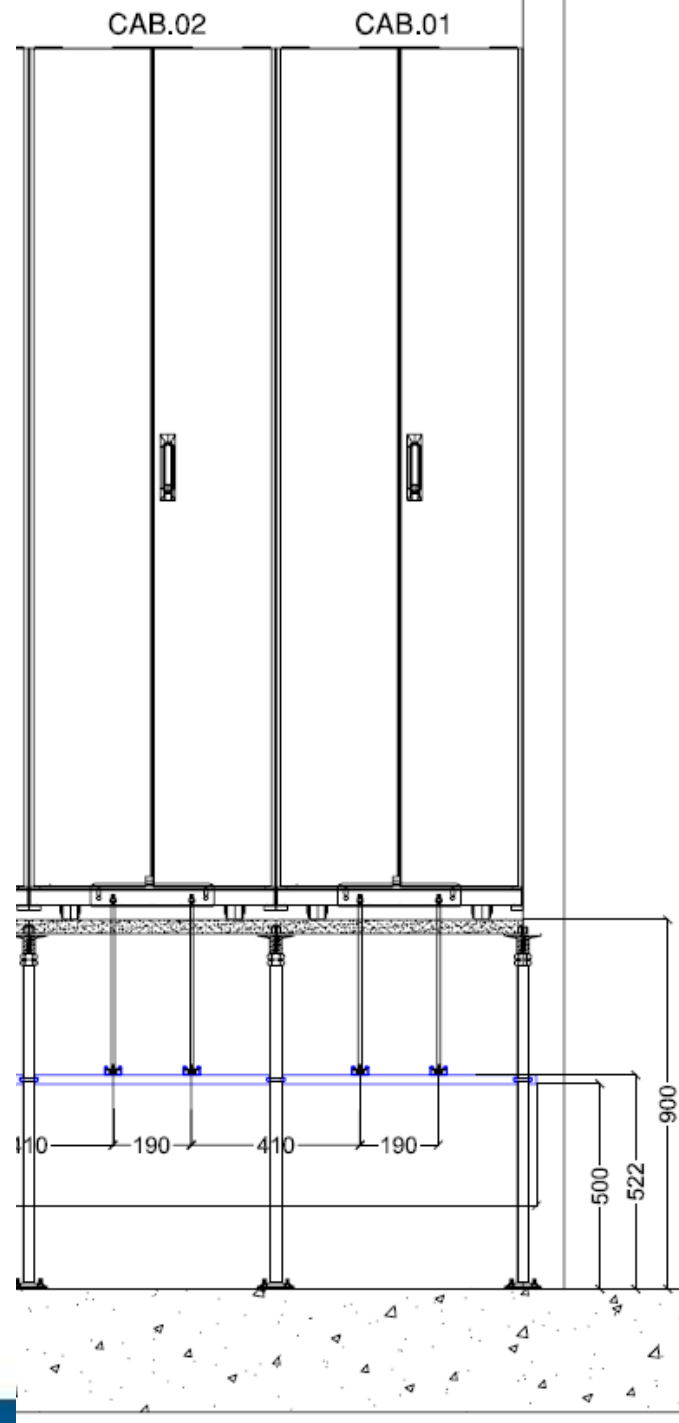

drilling into slab

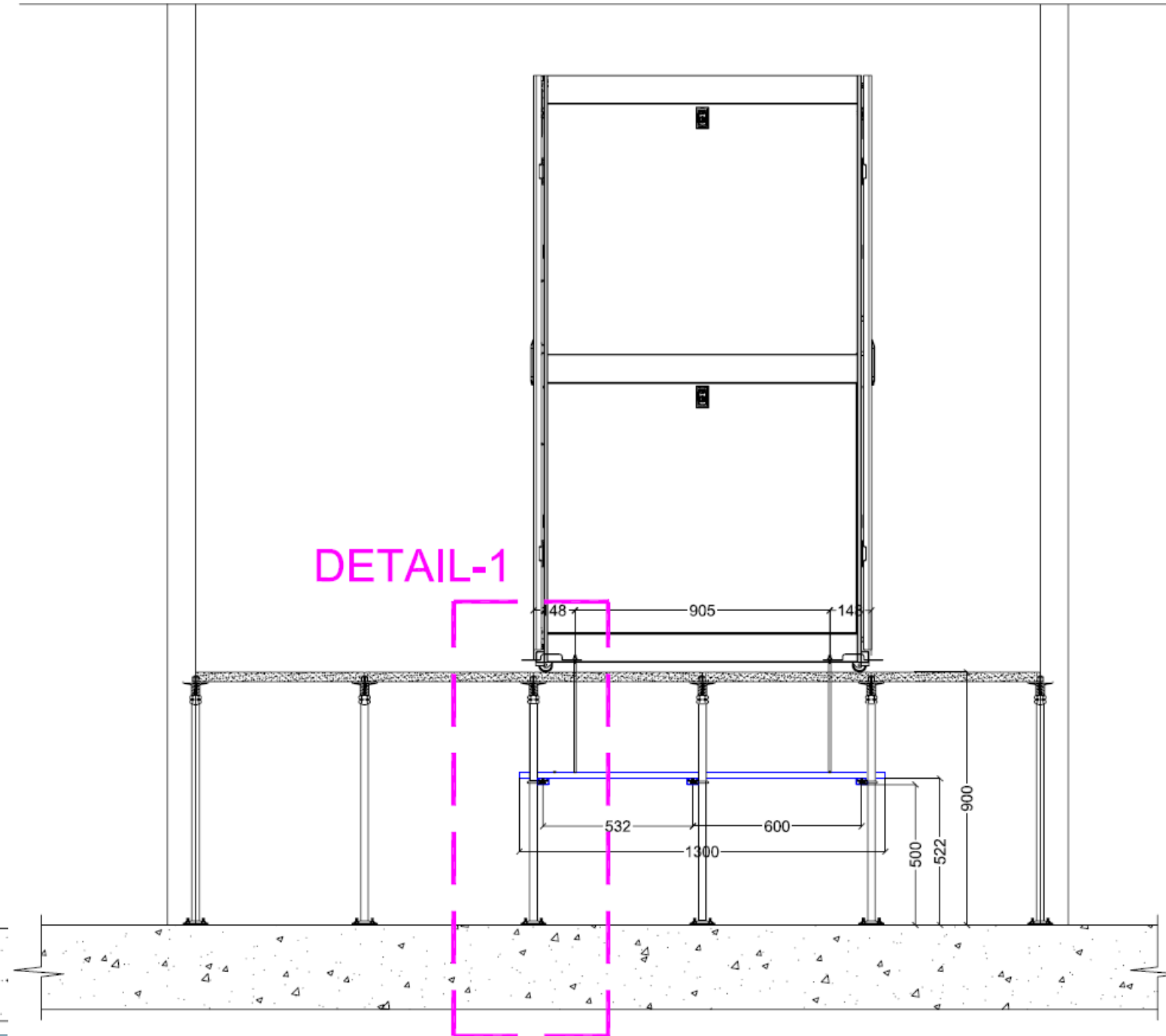



Example of Seismic Bracing where colo doesn't permit drilling into slab

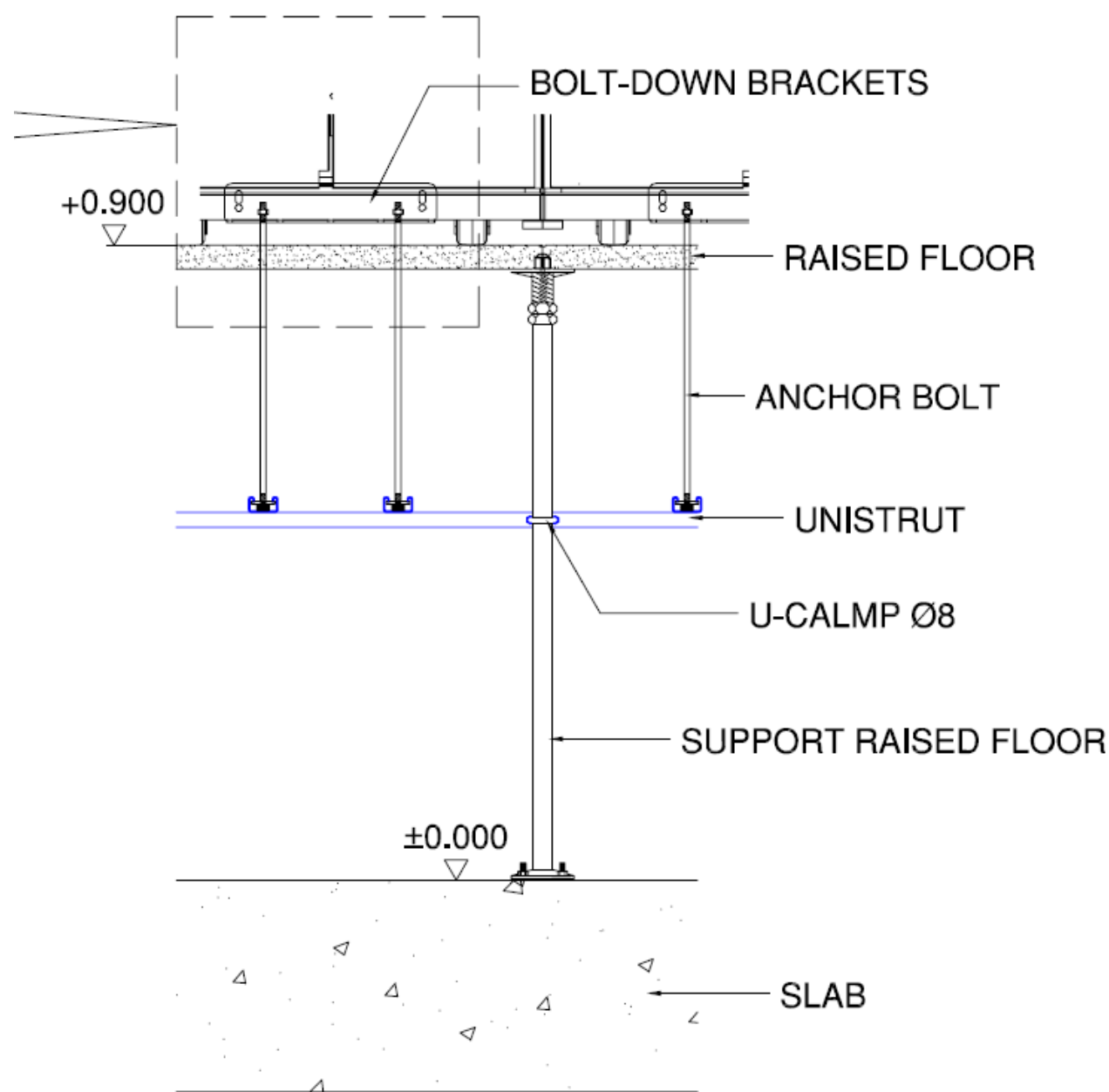

FRONT VIEW

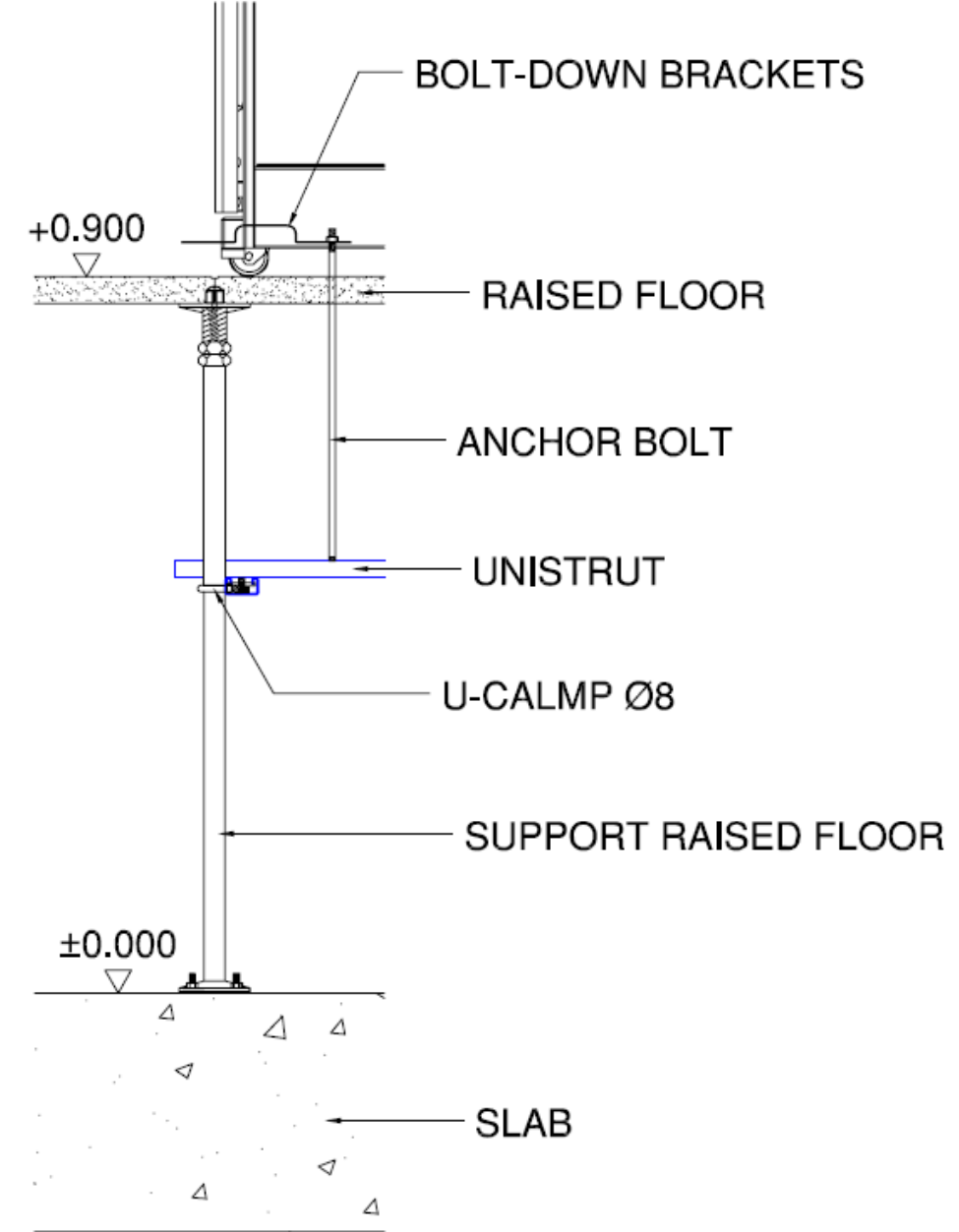

SIDE VIEW



5. Cabinets

If colocation facility provides cabinets what are

1. Cabinet manufacturer and model number(s)
2. Dimensions (height, width, length)
 - a. 600 mm cabinet adequate for servers
 - b. May need 800 mm for distributors/networking
3. Usable rack units (RUs)
4. Maximum load rating(s)
5. Accessories installed (e.g., for cable management, cooling) – is more cable management required?
6. Default rail locations – can we specify them to be moved?
 - a. Need rails set back for network & distributor cabinets (~250 mm)
 - b. Front to rear rail spacing of 736 mm works for most equipment





Example Cabinet Rail Locations – Network & Distributor cabinets

- 800 w (32") x 1200 mm (48") deep
- Front rails – set back 257 mm (10.1 inches) from the front of the frame
- Rear rails – 736.6 (29 inches) from the front rail
- Both power strips (RPDUs) on right rear side

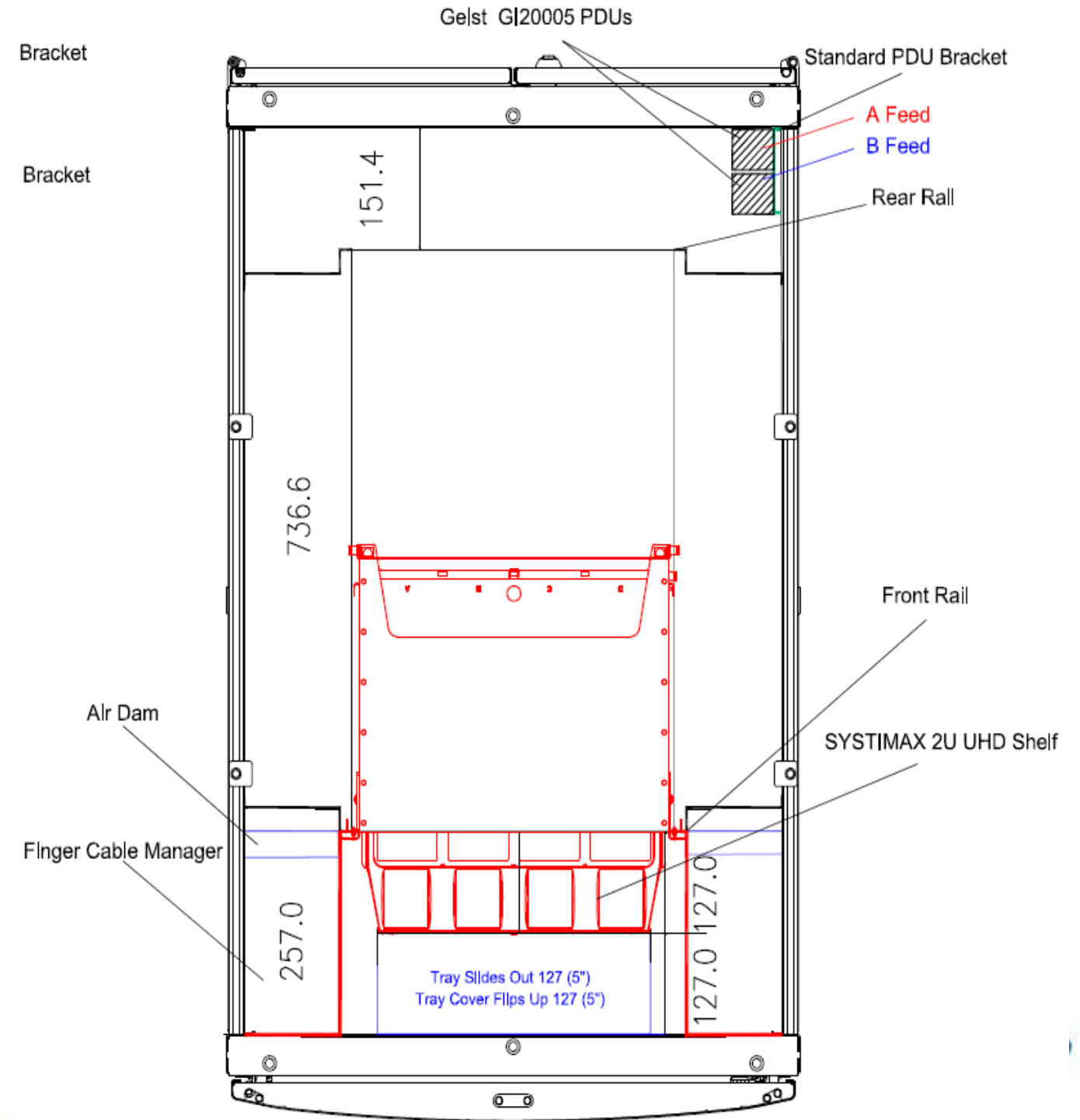



Example Cabinet Rail Locations – Server Cabinets

- 600 w (24") x 1200 mm (48") deep
- Front rails – set back 33 mm (1.3 inches) from the front of the frame
- Rear rails – 736.6 (29 inches) from the front rail
- Both power strips (RPDUs) on right rear side

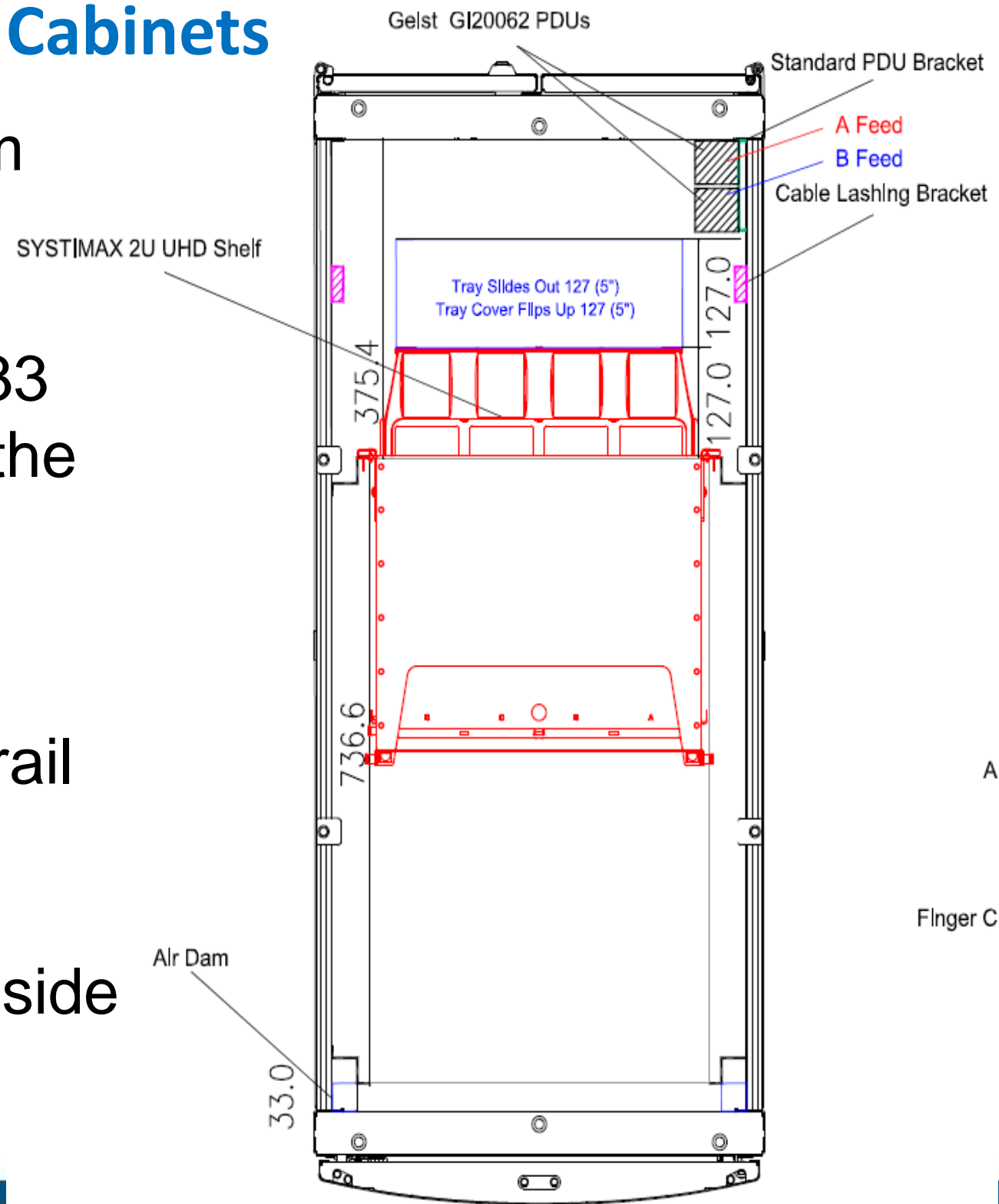



5. Cabinets

7. What type of racks and cabinets are permitted? For example, some colos specify that only cabinets with vertical exhaust ducts are allowed, no racks.
8. What type of containment is required?
 - a. No containment required
 - b. Cold-aisle containment, but with no roof required
 - c. Cold-aisle containment with roof
9. If containment with roof is required determine requirements for fire protection (commonly, the roof panels must drop if there is a fire)

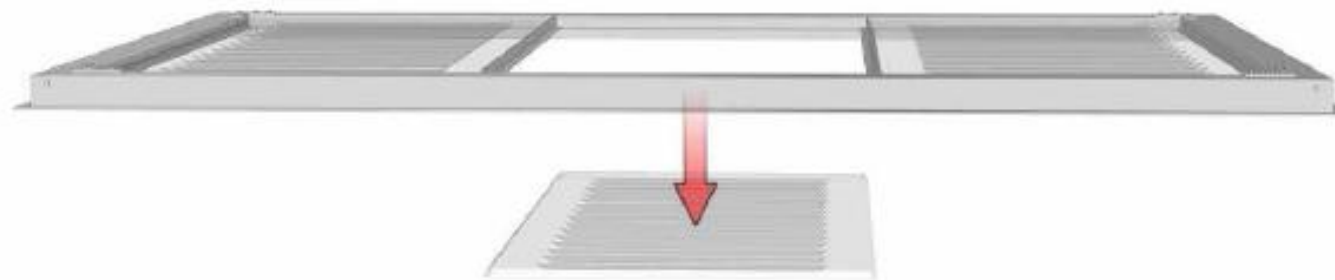

Roof panel that shrinks & drops if there is a fire



6. Meet-Me / POP Rooms

1. What are the number and location of Meet-Me Rooms (MMRs) or Point-of-Presence (POP) Rooms that will serve the cage/suite (should be at least 20 meters apart)
2. What is the route for cabling from these rooms to the cage/suite (should be diversely routed and not overlap)
3. What degree of protection do I require for this cabling and can the colo provide the required protection (e.g., EMT conduit from MMR/POP to cage/suite with no shared pull boxes) – all pull boxes with locks unique to customer
4. What is the identification information for the carriers to order circuits to each MMR/POP? (you will need different information for each room to manage where each circuit terminates)



6. Meet-Me / POP Rooms

5. Is the customer permitted to install their own patch panels or cabinets in the MMR/POP rooms? (Some customers such as carriers, ISPs, or owners of large suites, want responsibility for the circuits from the carrier demarcation point in the MMR/POP to the suite/cage)
6. If the customer desires and is permitted to install cabinets in the MMR/POP rooms, request floor plans and proposed locations for cabinets in these rooms
7. If the customer desires and is permitted to install patch panels (but use the colo cabinets/racks), then request the floor plan, cabinet ID, and RU locations for the patch panels
8. Cabinets and patch panels in colo MMR/POP rooms may have locks for additional security



6. Meet-Me / POP Rooms

9. Which carriers/service providers can provision circuits to each MMR/POP?
10. What type of circuits can each carrier provide in each MMR/POP. Many colos can only provision telephone lines from one room.
11. Is there are need to install cabling and antennas for satellite, network timing, microwave radio, or other services? If so, specify antenna location, mounting, and cabling requirements to colo.
12. Specify any requirements for conduits for antenna cabling, security cabling (badge readers, cameras, cabinet locks) and DCIM (PDU & air conditioning controls/monitoring)



6. MMR/POP Room Conduit Routes

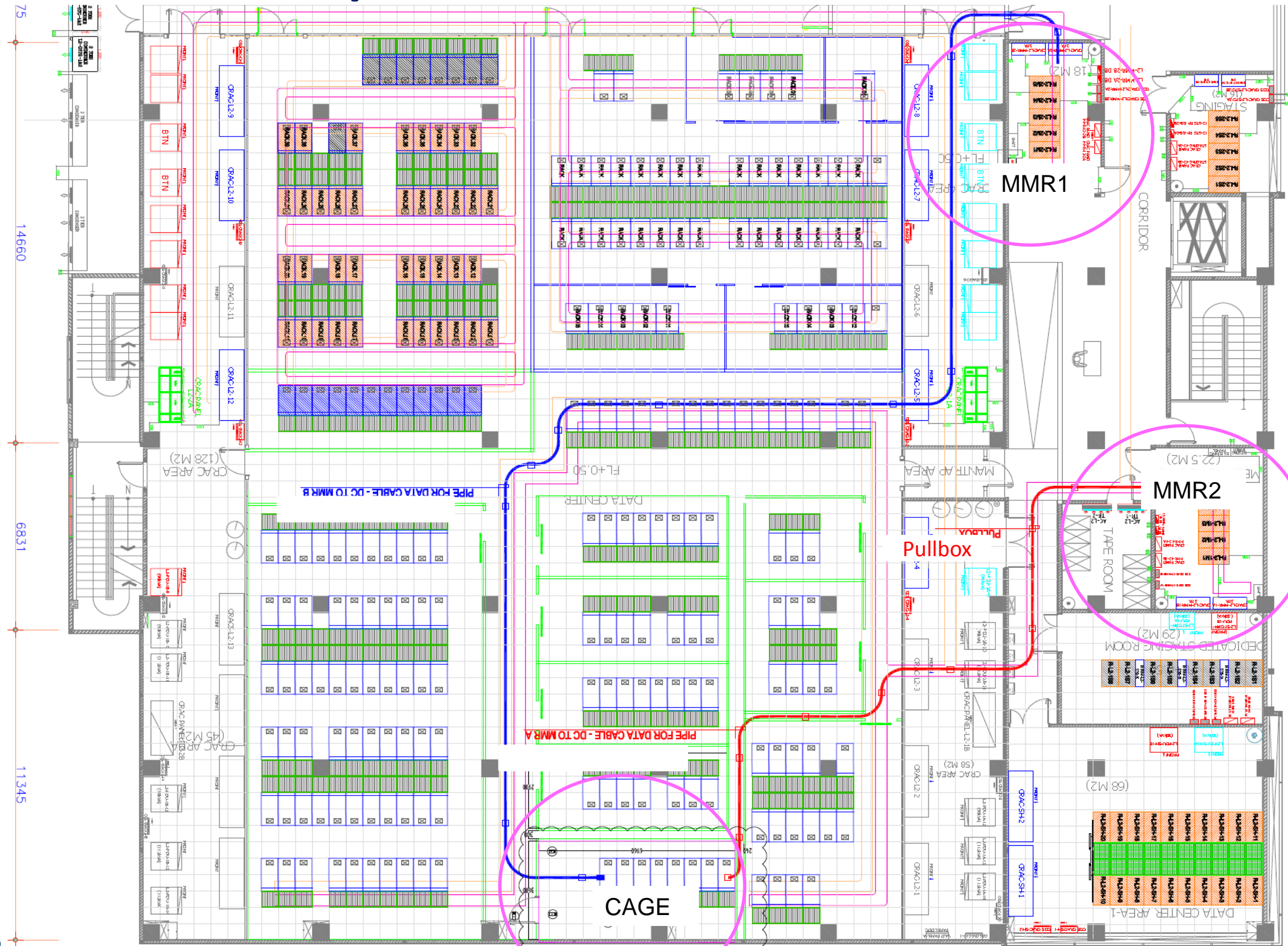



7. Cabling from MMR/POP Rooms

1. Who is responsible for installing cabling from MMR/POP rooms to customer cage/suite?
2. How is the customer charged for the cabling (one-time cost only, one-time cost + monthly recurring, monthly recurring only)
3. If carrier installs cabling, specify exactly the cabling required from the cage/suite to each MMR/POP room (type, quantity, connectors):
 - a. Single-mode optical fiber (for carrier and campus connections) – typically LC/UPC, but may be LC/APC (angled) for broadcast video, wave division multiplexing, other
 - b. Multimode optical fiber (used by some carriers for Ethernet connections) – typically LC
 - c. Balanced twisted pair (for telephone lines, fractional-E1/T1, E1/T1, some Ethernet connections from carriers) – typically on 8-pin modular jack (RJ45)



7. Cabling from MMR/POP Rooms

4. Assign size, cabinet location and RU location of patch panels to MMR/POP in cage/suite. Some colos may allow customer to specify model # of panel.
5. Size and type of conduits (e.g., 100 mm EMT) and innerducts (if desired and if optical fiber cables are not armored)
6. Colo to specify cabinet ID, patch panel, & ports for terminations in MMR/POP (used to specify cross-connects of circuits to cage)



Example of conduits & cabling provided by colo

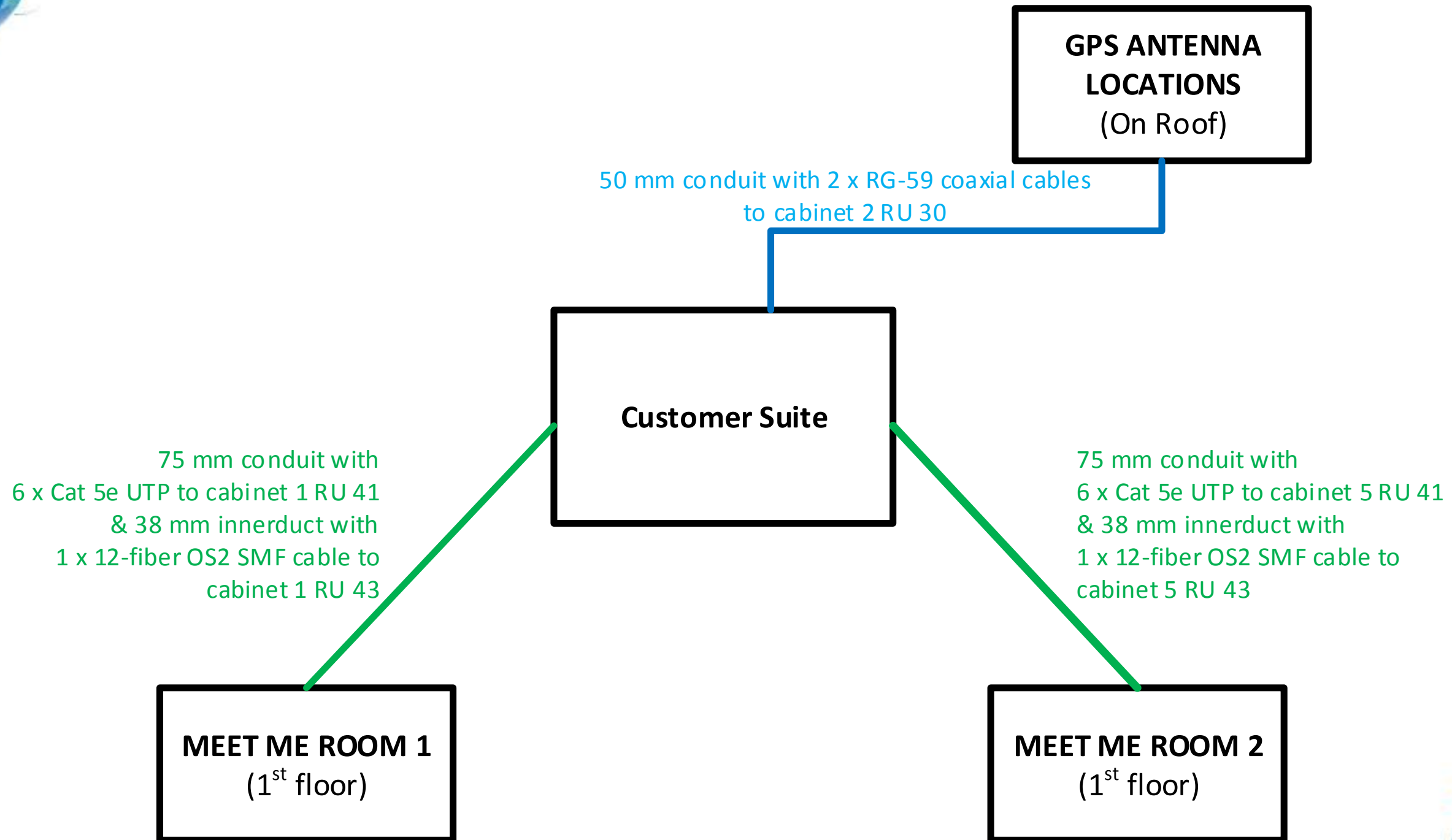

Colo Patch Panel Locations in Customer Cabinets

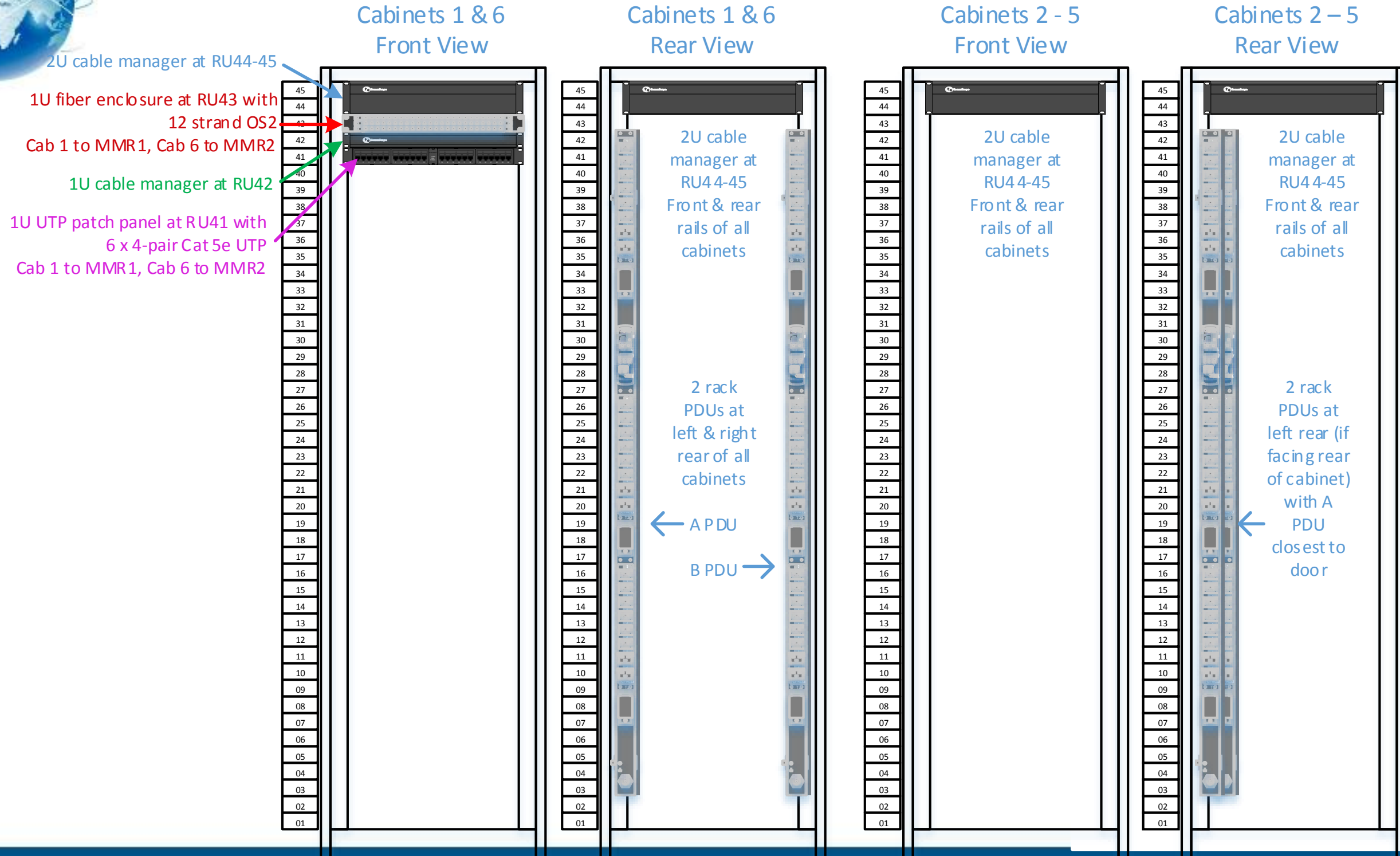



8. Cabling & cabinets within cage

1. Customer typically responsible for cabling within the cage, but this may be outsourced to colo
 - Customer will need to specify exactly the cabling required including type, quantity, termination hardware, cabinet ID and RU location of patch panels
2. Cabinets may need to be secured to the slab (or raised floor system) – who performs this work?
 - Customer will need to specify exactly where cabinets are to be located, exact locations typically required for containment systems to work
3. Cabinets may need floor tile cuts for bonding conductor, power cables, and telecommunications cabling
 - Customer will need to specify type and location of tile cuts
 - Determine manufacturer & model # of grommet used by colo



Cabinet Location

- In this example exact cabinet location is important for end cap and containment doors to fit

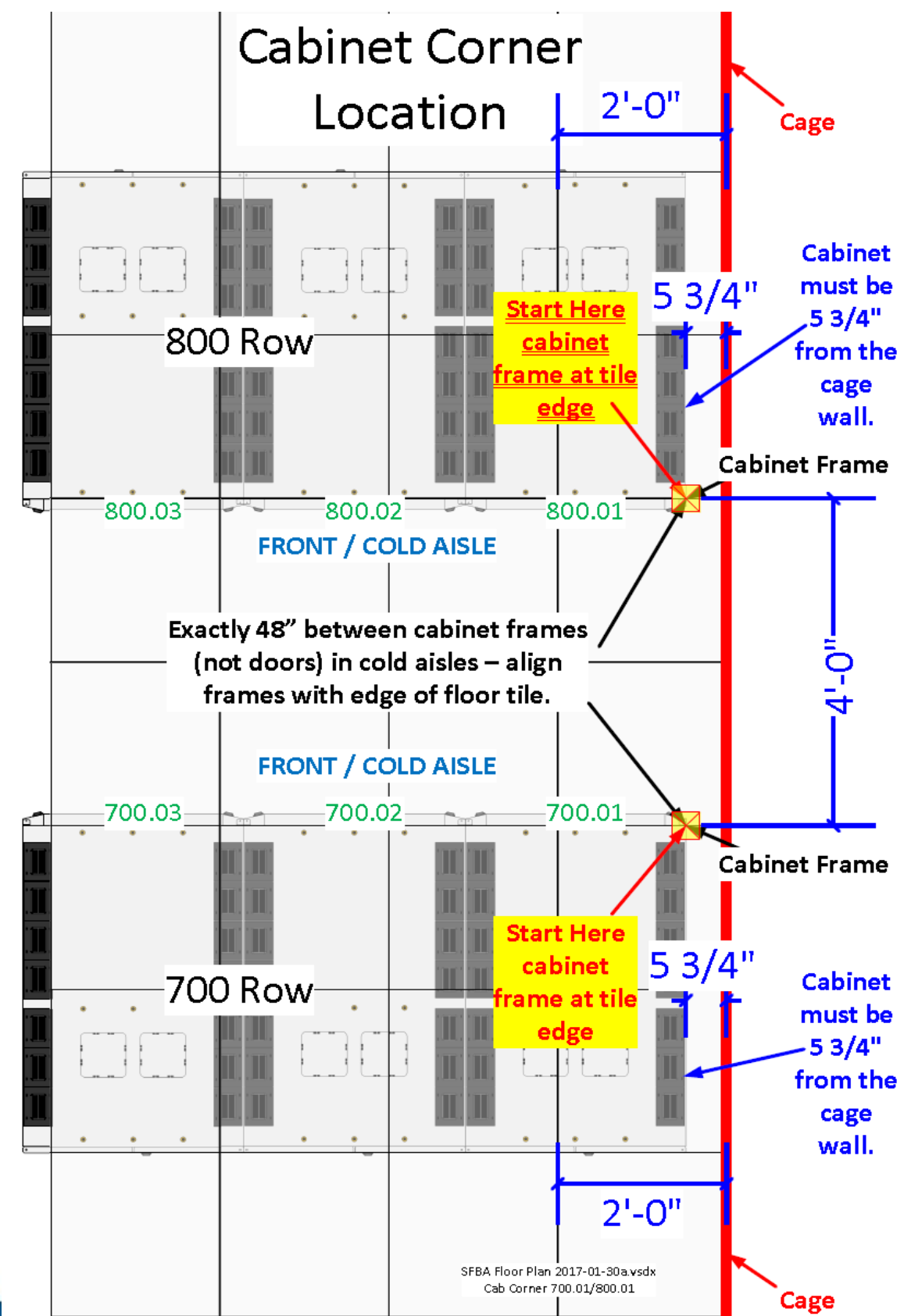



Tile cut example

FRONT / COLD AISLE

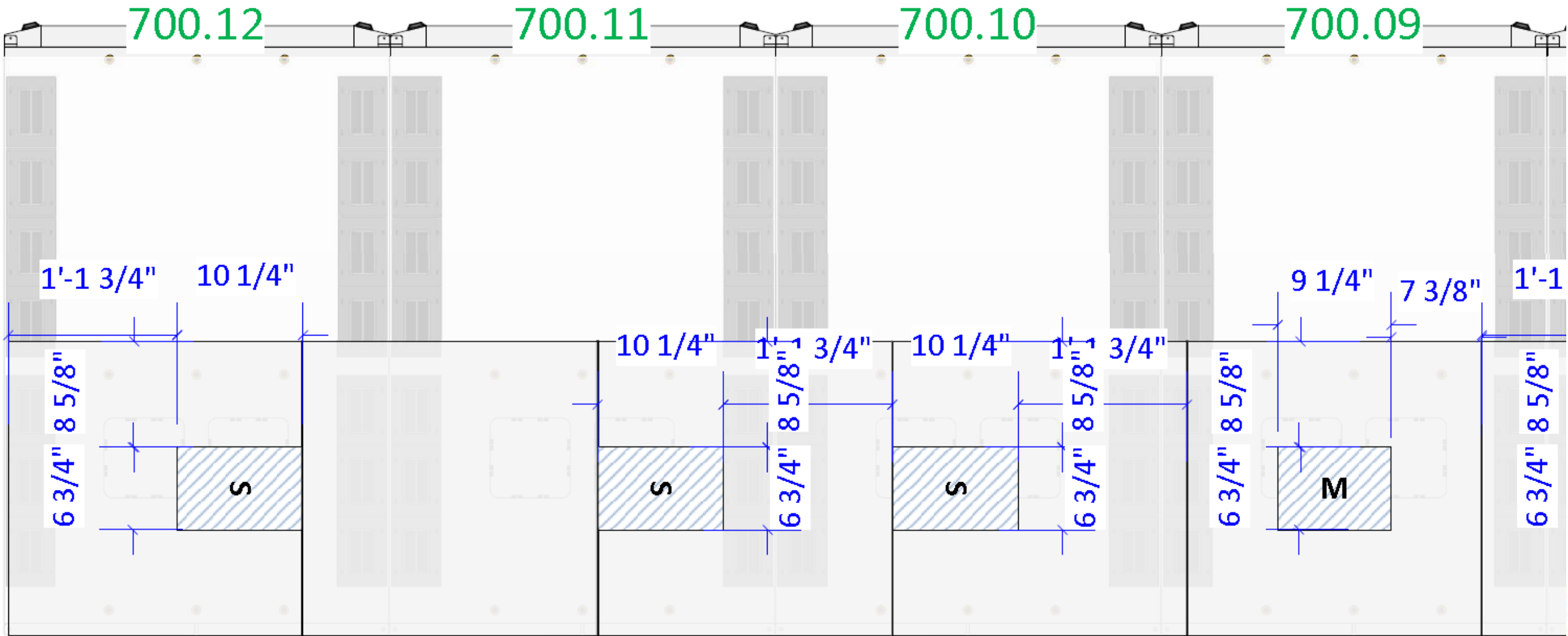



8. Cabling & cabinets within cage

4. Determine who is responsible for bonding each cabinet (using 6 AWG / 16 mm²) stranded bonding conductor for each cabinet. Many colos do not allow customers to perform work under the raised floor
5. If customer is responsible for bonding conductors, you will need to know size of conductors (for sizing taps) and location of mesh-BN (height and horizontal distance) relative to the cabinets (for lengths of bonding conductors)

H-Tap sized
for two
conductors
being joined



Optional tap
cover



9. Power

1. Where and how is power distributed (e.g., power whips under the floor, overhead in cable trays, overhead using electrical bus, other) – obtain elevation showing location of power – ensure adequate separation from copper cabling
2. Determine who is responsible for providing cabinet PDUs/power strips.
3. If the colo provides the cabinet PDUs – what is the model #, # of phases, number of receptacle, and type of receptacles
 - Confirm that the # and type of receptacles matches equipment

C13/C14 coupler



C19/C20 coupler





9. Power

4. Who is allowed to plug cabinet PDUs/power strips into the receptacles under the floor? Be certain that cabinet PDUs are labeled with the PDU/RPP and breaker of the electrical receptacle
5. Customer should provide electrical requirements (kW load for each cabinet). Load may require replacement of single-phase circuits with 3-phase circuits or additional circuits.
6. If customer provides cabinet PDUs, provide colo with number, type, and location of receptacles



IEC 60309 (IEC 309) 3P+N+G 32Amp(532P6)

IEC 60309 (IEC 309) P+N+G 32Amp(332P6)





Power Separation

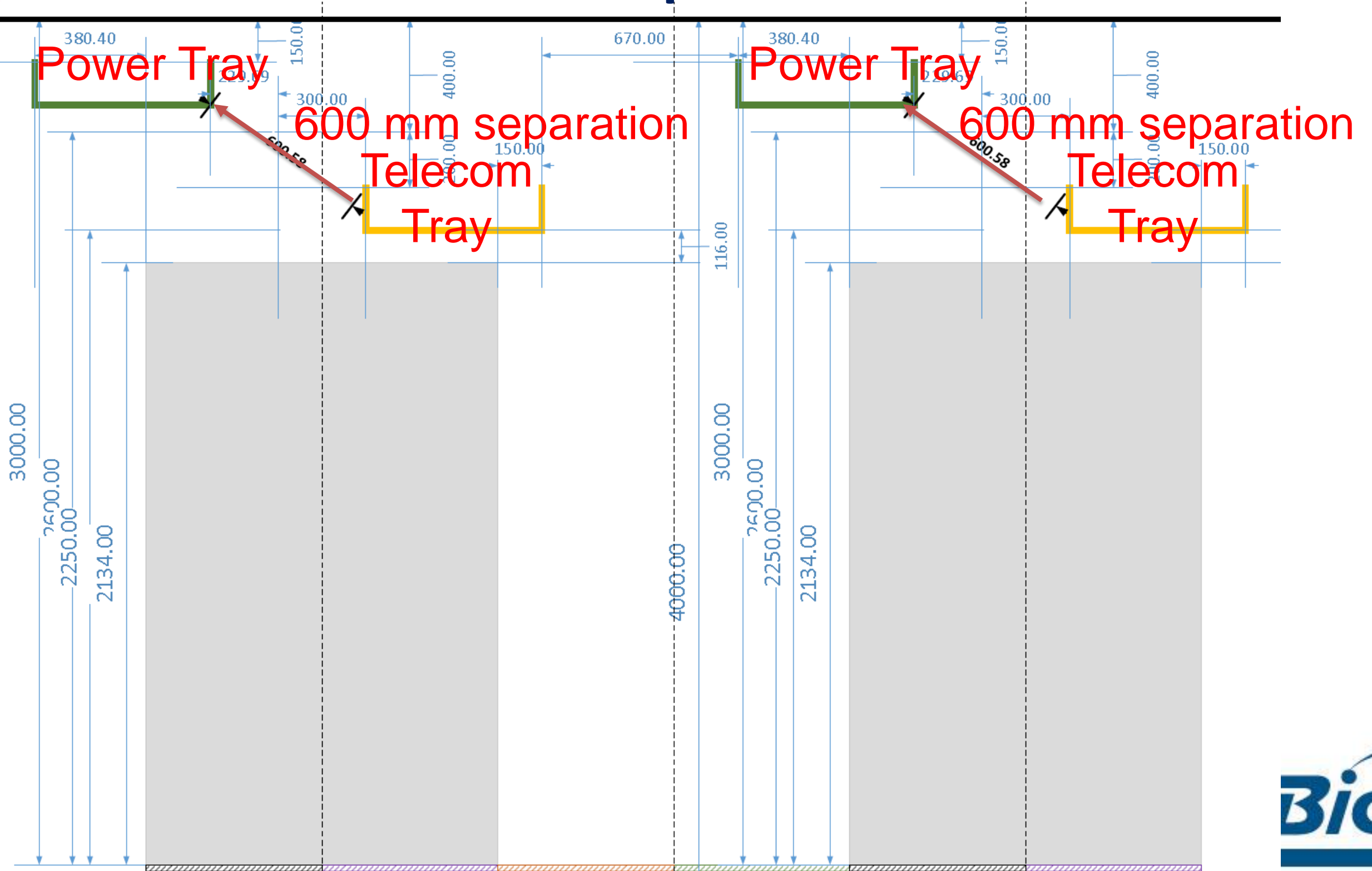



Receptacle Requirements & kW Loads (on spreadsheet or drawing)

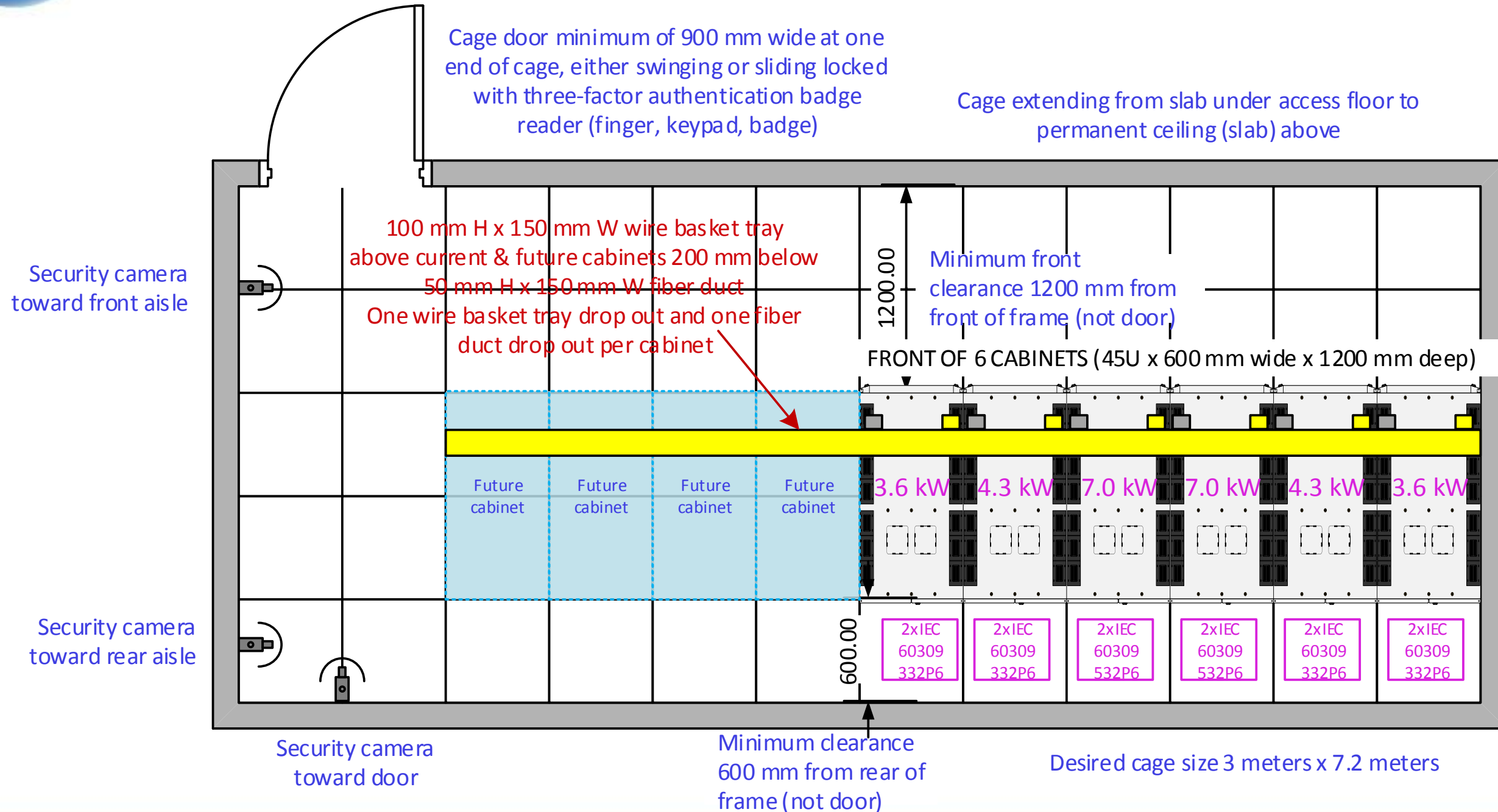



9. Power

7. Some customers are responsible for Remote Power Panels (RPPs) and/or breakers
8. Need to determine responsibilities for purchase, acquisition, and monitoring
9. Some colos provide monitoring (e.g., circuit level monitoring, temperature) – determine what colo monitors and how reports can be provided to the customer





10. Security



1. Building security - what type of security does the building have at all entrances?
2. Room security – what type of security is used within the building to critical rooms (computer room, electrical, mechanical, MMR/POP) card reader, biometric, cameras, audit trail, anti-tailgating, anti-passback?
3. What type of locks are used for access to the customer cage - physical lock, badge reader, audit trail?
4. Access to badge reader logs – if badge reader is controlled by colo, how long are access logs kept and how can customer request logs to cage/suite?
5. Security cameras - specify locations, who monitors video?
6. Video storage duration – if colo owns and monitors camera, how long is security video stored and how can the customer request video?





10. Security

7. Type of cage or wall material for the customer cage/suite?
8. What can other customers see or access (maybe with a stick or tool) through the cage?
9. What is the height of the cage – does it reach to the false ceiling, permanent ceiling, or below it?
10. Does the wall or cage reach below the raised floor? If not what prevents someone from entering the cage or suite from below (e.g., bolted tiles) or from unplugging receptacles below cage?





11. Storage & staging

1. How much temporary storage space is available?
2. What is the procedure for access to the storage room?
3. Where can the customer stage equipment for unboxing, building, and configuring gear?
4. What are the procedures and rules for the staging area?





12. Loading Dock

1. What is the size of the loading dock what is the maximum size vehicle that it can accommodate?
2. Are lift gates needed/not needed?
3. What are the scheduling procedures for deliveries, loading dock, and/or elevators - are there limited hours?
4. Does the building require certificate of insurance from the company performing the deliveries for deliveries of equipment inside the computer room?
5. For industrial pallet jacks and electric forklifts, the recommendation is a slope no more than 14% (1:7.14 ratio) or about 8 degrees.





13. Work Rules & Procedures

1. Access procedures – procedures for access for customer employees, contractors, or vendors
2. Working under access floor - procedures regarding alarms, notification, tools
3. Types of work not permitted by the customer or customer contractors
4. Other work rules / procedures
5. How to request work orders by the colo
6. Expected turnaround time for quotes and turnaround time for completing





14. Conclusion

1. Moving into a colocation facility requires detailed and careful planning
2. Make sure that you and the colo clearly understand your requirements
3. Obtain the information needed from the colo to plan properly
4. Provide the colo with the information that they need
5. Ensure that the colo can meet your requirements before finalizing selection
6. Requirements should be specified in contract documents





Questions?

Jonathan Jew

President J&M Consultants, Inc.

Website: www.j-and-m.com

Email: jew@j-and-m.com

Co-chair BICSI data center subcommittee

Editor TDMM 13th Edition Telecom Administration

Chair TIA TR-42.6 telecom administration subcommittee

Vice-Chair TIA TR-42.3 pathways & spaces

Vice-chair USTAG to ISO/IEC JTC 1 SC 25 WG 3

Editor ISO/IEC TR 14763-2-1 telecom admin identifiers

SME BICSI TI&M Telecommunications Administration

Secretary TIA TR-42

