

Advanced AV System Trends, Technology & Design Considerations for Datacom Professionals



Today's Agenda



- Introductions and overview
- AV Science
 - The Phi phenomenon
 - Temporal resolution in AV systems
 - HDR and deep color
 - Radiometric resolution in AV systems
 - Spatial resolution in AV systems
 - Calculating digital video bandwidth
 - PISCR, DISCAS and other AVIXA standards
- AV Connection Methods
 - Accounting for HDCP
 - HDMI Technical Deep Dive
 - DisplayPort Technical Deep Dive
 - USB 1.1 & 2.0 Technical Deep Dive
 - USB Type-C & 3.1 Gen 2 Technical Deep Dive
- AV Transport Methods
 - HDBaseT Technical Deep Dive
 - AV-over-IP Technical Deep Dive
- Summary and Q&A

Four Vectors of A/V Communication



Experience Architecture



The AV Quality Triangle

“Machines take me by surprise with great frequency.” – Alan Turing



Resolution

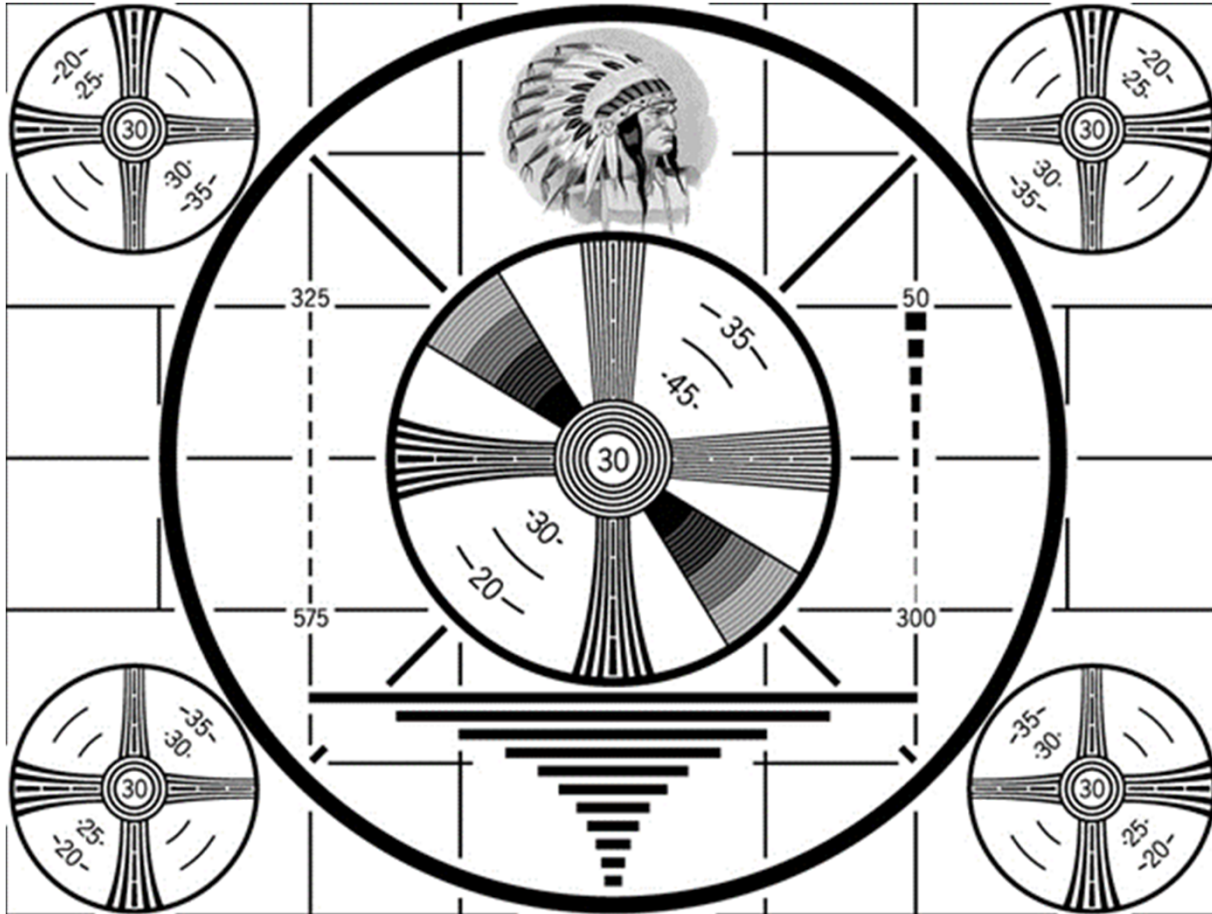

Spatial Resolution

- Each pixel on a screen could be considered an optotype element
- Depending on the quality of the content, the recommendations of the past are often inadequate to enable maximum viewable image information intake



Radiometric Resolution



2-bit = 4 radiance levels



8-bit = 256 radiance levels

Deep Color

- xvYCC (also x.v.Color) is a color space used in the video displays to support a gamut 1.8 times as large as that of the sRGB color space.
 - Proposed by Sony, specified by the IEC in October 2005 and published in January 2006 as IEC 61966-2-4

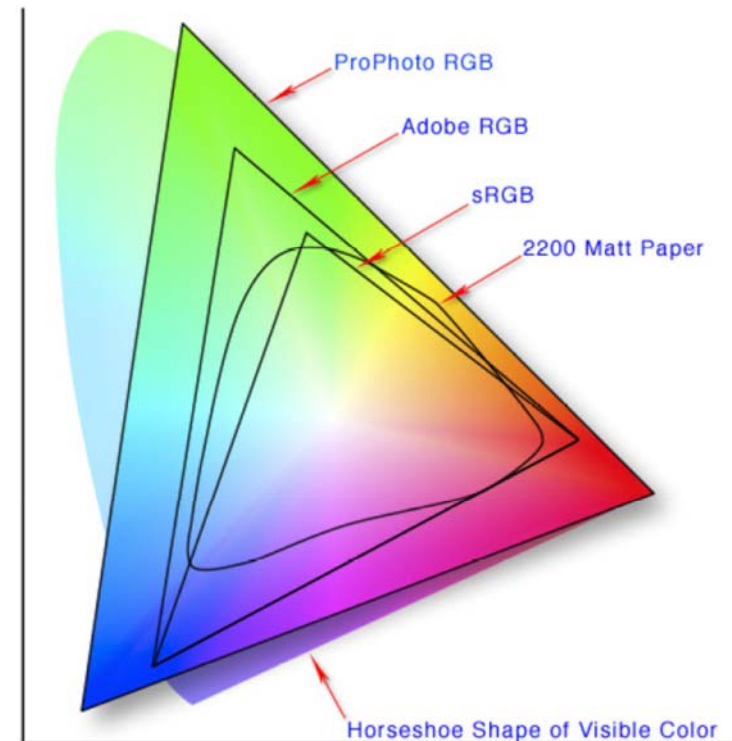

HDR – High Dynamic Range Imaging

Visible color spectrum and coverage of display standards

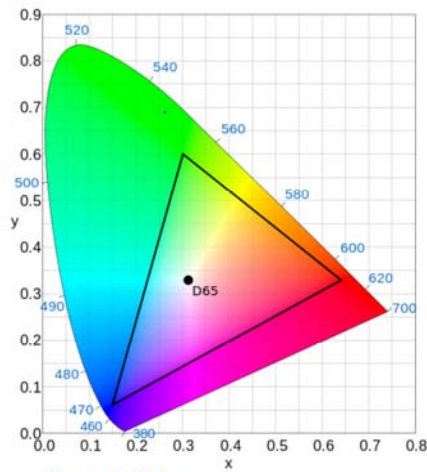

Rec. 709
35.9% of visible spectrum

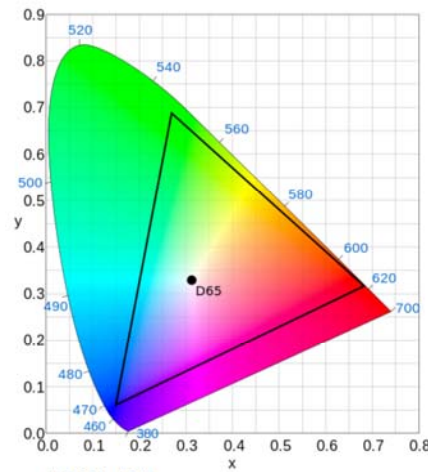

DCI-P3
45.5% of visible spectrum

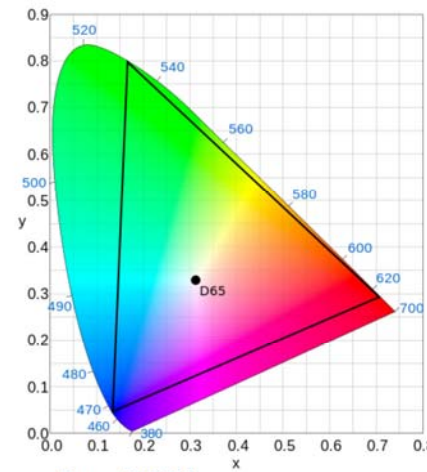

Rec. 2020
75.8% of visible spectrum

Graph: CIE 1931 color space. Percentages from Steve Withers of avforums.

Reproduces a greater dynamic range of luminosity than is possible with standard digital imaging techniques.

Color Space

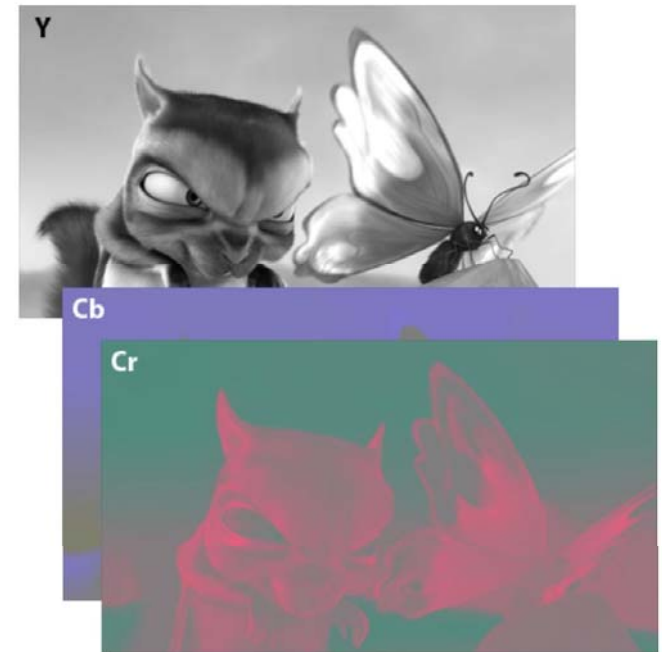

Most content is in 4:2:0 space where, if the resolution of the overall image is 1920×1080, the Cb and Cr portions of the image will be at 960×540 resolution

RGB

Y Cb Cr (4:4:4)

RGB to 4:4:4

Radiometric – HDR, Deep Color

 **legrand**



LCD, LED or OLED?

- LCD displays achieve a minimum **20,000:1** contrast ratio
- 1000 cd/m² - black level below 0.05 cd/m²
- sRGB spec for monitors targets 80 cd/m²
- OLED displays achieve a minimum **1,080,000:1** contrast ratio
- 540 cd/m² - black level below 0.0005 cd/m²



Temporal Resolution

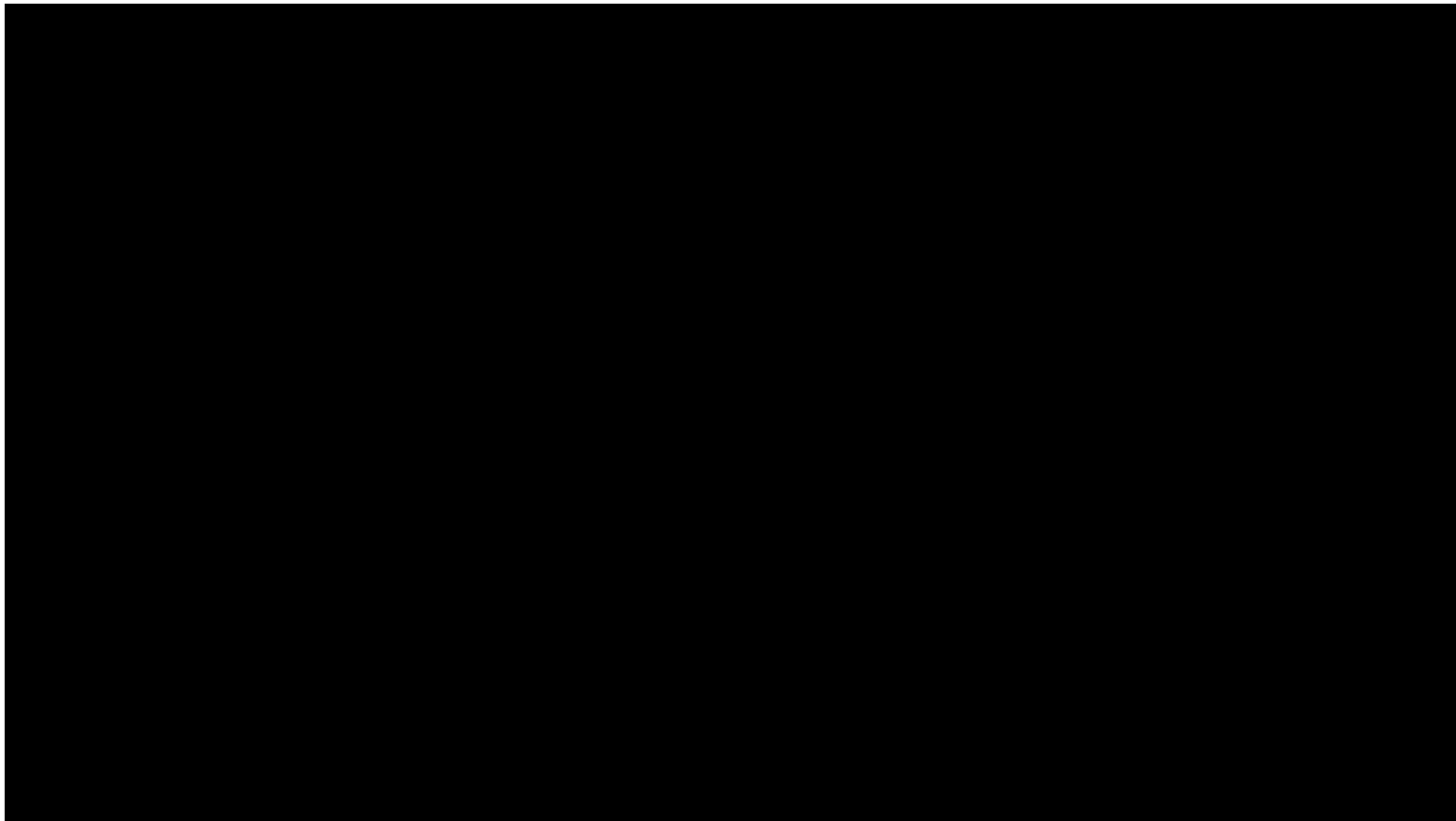

Temporal - Fps



Bandwidth Must Be Examined More Closely in the New 4K World

- “Old” Formula to calculate analog video bandwidth
 - $H_p * V_p * F_r * 3 / 2$
 - There is no correction for **bit depth** or **dark pixels**
 - This formula is a holdover from analog days

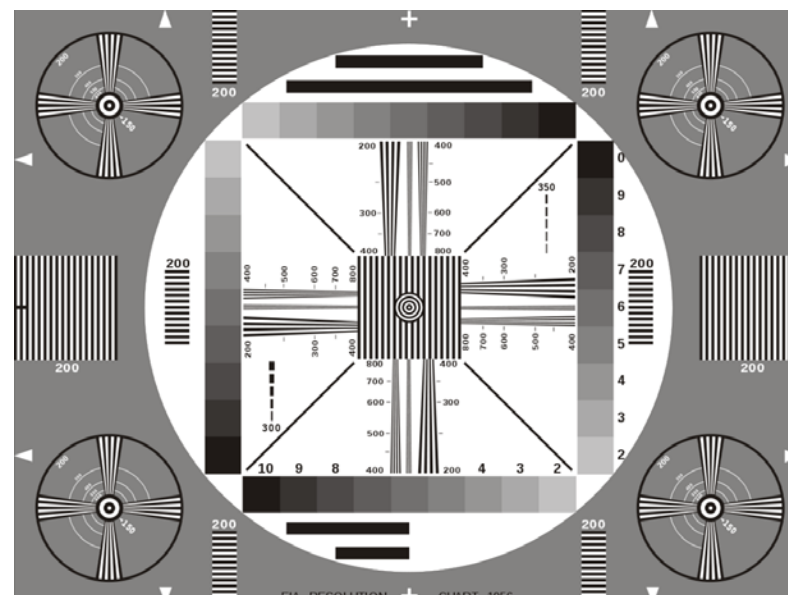

$$H_{pf} * V_{pf} * F_r * B_d(*cf) * M * 3 * Q$$

HDMI uses 8b/10b line coding, which is a line code that maps 8-bit words to 10-bit symbols to achieve DC-balance and output bounding. 8b/10b line coding increases the number of bits per color component by a factor of 1.25 (10/8). The 24-bit color we take for granted is a 10-bit per sub-pixel value across each of the RGB channels

H_p = Horizontal Pixels

V_p = Vertical Pixels

F_r = Frame Rate

B_d = Bit Depth

cf = chroma decimation factor

M = deep color factor

Q = Compression

the information comes from the CEA-861 specification

Rate (Hz)	Active	Vactive	Color Depth	Prog/ Inter	Htotal	Hblank	Vtotal	Vblank	Rate (Hz)	Pixel Freq. (MHz)
50	1440	576	24	I	1728	288	625	49	0.6	27
50	1440	288	24	P	1728	288	312	24	0.6	27
50	1440	288	24	P	1728	288	313	25	0.6	27
50	1440	288	24	P	1728	288	314	26	0.7	27
50	2880	576	24	I	3456	576	625	49	1.3	54
50	2880	288	24	P	3456	576	312	24	1.3	54
50	2880	288	24	P	3456	576	313	25	1.3	54
50	2880	288	24	P	3456	576	314	26	1.3	54
50	1440	576	24	P	1728	288	625	49	1.3	54
50	1920	1080	24	P	2640	720	1125	45	3.6	149
50	2880	576	24	P	3456	576	625	49	2.6	108
50	1920	1080	24	I	2304	384	1250	170	1.7	72
60	640	480	24	P	800	160	525	45	0.6	25
60	720	480	24	P	858	138	525	45	0.6	27
60	1280	720	24	P	1650	370	750	30	1.8	74
60	1920	1080	24	I	2200	280	1125	45	1.8	74
60	1440	480	24	I	1716	276	525	45	0.6	27
60	1440	240	24	P	1716	276	262	22	0.6	27
60	1440	240	24	P	1716	276	263	23	0.6	27
60	2880	480	24	I	3432	552	525	45	1.3	54
60	1920	1080	24	P	2200	280	1125	45	3.6	149
60	2880	480	24	P	3432	552	525	45	2.6	108
100	1920	1080	24	I	2640	720	1125	45	3.6	149
100	1280	720	24	P	1980	700	750	30	3.6	149
100	720	576	24	P	864	144	625	49	1.3	54
100	1440	576	24	I	1728	288	625	49	1.3	54
100	1920	1080	24	P	2640	720	1125	45	7.1	297
120	1920	1080	24	I	2200	280	1125	45	3.6	149
120	1280	720	24	P	1650	370	750	30	3.6	149

check also http://wiki.osdev.org/File:VGA_crtc.gif

Some Examples

- Calculate the video data signaling rate for a UHD 2160p60 signal operating in a 4:2:0 color space
 - $4120 * 2205 * 60 * (10 * .5) * 1 = 2,727,380,000$ per RGB color channel
 - $(2.73 \times 3) = 8.19$ Gbit/s total payload rate
 - This is uncompressed. Multiply by Q for compression
- Calculate the video data signaling rate for an HD 1080p60 signal operating in a 4:4:4 color space
 - $2200 * 1125 * 60 * (10 * 1) * 1 = 1,485,000,000$ per RGB color channel
 - $(1.49 \times 3) = 4.47$ Gbit/s total payload rate
 - This is uncompressed. Multiply by Q for compression

The AV Signal Quality Triangle

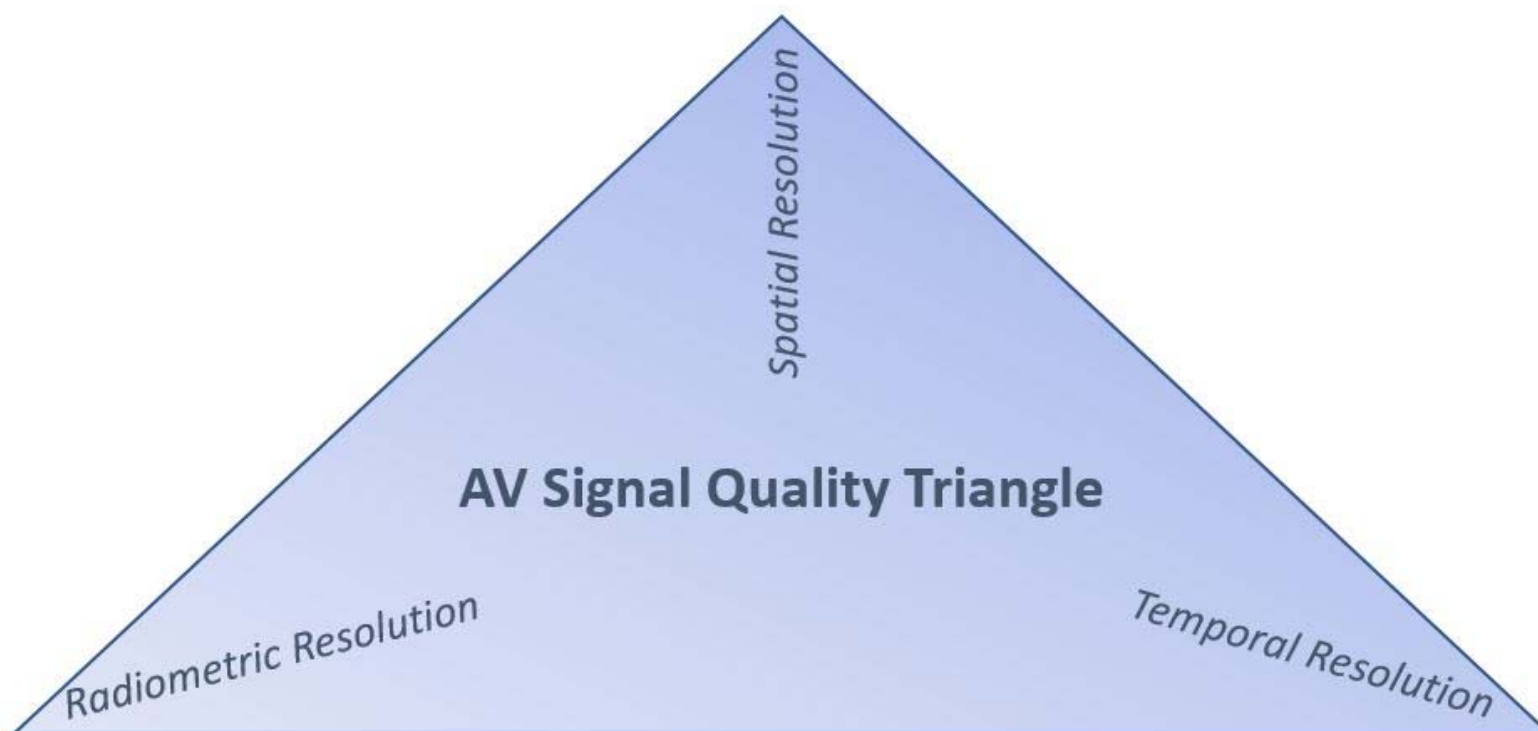

The New ANSI/AVIXA Standard – DISCAS

The goal of DISCAS is to create a scientific standard, based on human vision, to define the screen size for a given audiovisual system based on audience viewing distance.



DISCAS Help Define “Resolution” Needs

- DISCAS is a scientific standard, based on human vision, that defines the screen size for a given audiovisual system based on audience viewing distance.
- ANSI/AVIXA V202.01:2015 DS1 Display Image Size for 2D Content in Audiovisual Systems (DISCAS)

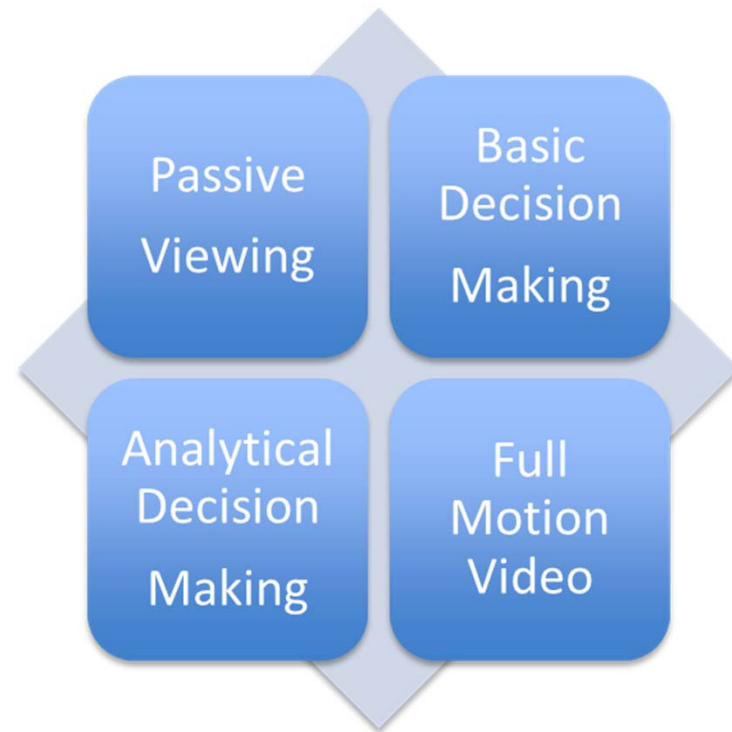

Why DISCAS?

•Comprehensive Human Factors for visual acuity and position relative to the image, including:

- Image Height
- Image Resolution
- Size of Image Content
- Closest and Farthest Viewer Distances
- Relative Horizontal and Vertical Viewing Locations

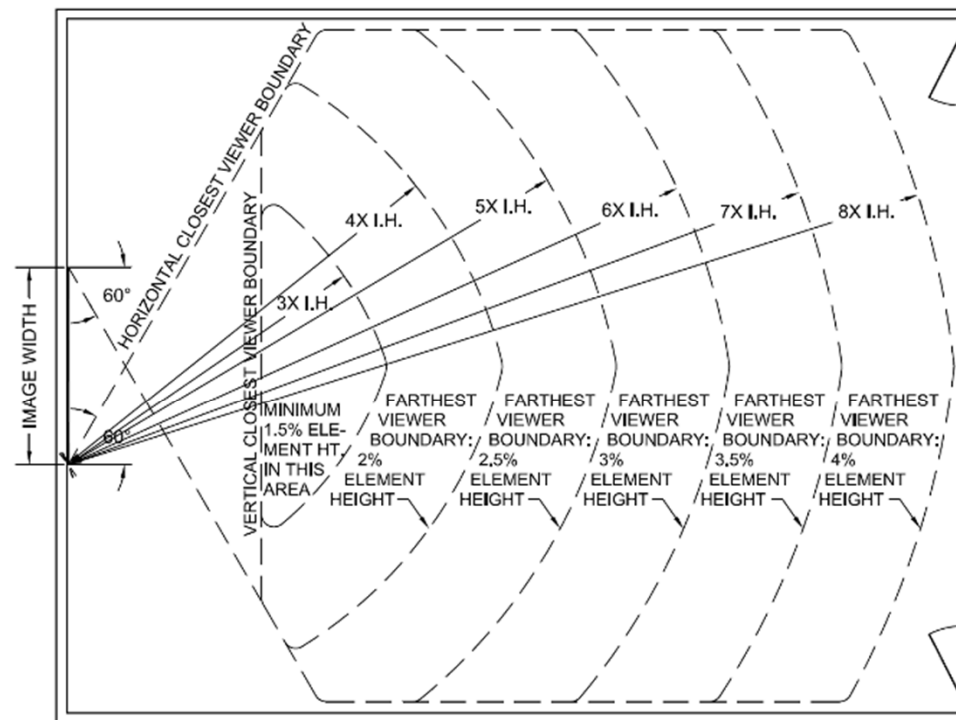

VIEWING PARAMETERS FOR BDM
 NO SCALE I.H. = IMAGE HEIGHT
 IMAGE HEIGHT BASED ON 16:9 (1.78:1) ASPECT RATIO

What is Analytical Decision Making?

- ADM is a more specialized calculation
 - Concerned with the finest of details
 - Pixel-level detail required
 - Used for things like medical imagery, technical drawings, and photographic evaluation



Basic Decision Making

- BDM is the most common type of viewing category and included most business and education applications
 - Concerned with overall content rather than fine detail
 - Legibility and content assimilation are key
 - Typical content includes PowerPoint, text, illustrative images, spreadsheets



A Practical Example

A project demands maximum visual information. What image resolution/size is required for a viewer, positioned 3 meters from the screen, to result in maximum appreciated visual detail (additional resolution no longer affects image appreciation)?

Calculate Image Size for Maximum Visual Detail

- ***Image Height*** = $\frac{\textit{Farthest Viewing Distance} * \# \textit{Vertical Pixels}}{3438}$
 - Image Height = $\frac{3 \textit{ meters} * 2160 \textit{ Vertical Pixels}}{3438} = 1.88 \textit{ meters}$

Therefore image height should be about 1.90m for maximum delivered visual detail, where additional resolution will not impact visual acuity.

A Practical Example

- A project demands maximum visual information. What is the maximum recommended viewer distance for an 85-inch diagonal-measure 16:9 4K flat panel?
- What if the panel is 2K?

Viewing Distance for Maximum Visual Detail

- *Farthest Viewing Distance* = $\frac{\text{Image Height} * 3438}{\# \text{ Vertical Pixels}}$
- *Distance to the farthest viewer* = $\frac{41 \text{ inches} * 3438}{2160} = 65.25 \text{ inches (5.4')}$
- *Farthest Viewing Distance* = $\frac{41 \text{ inches} * 3438}{1080} = 130.5 \text{ inches (10.8')}$
- *Therefore viewers between 5.4' and 10.8' may be well served by 1080p, but viewers closer than 5.4" should have a 2160p image*

How Do We Handle Basic Decision Making?

- *“Decisions are made by people who have time, not people who have talent.”*
 - Scott Adams

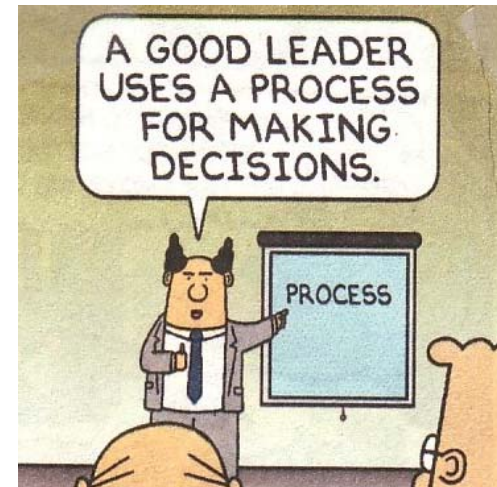

Calculating The BDM_{AF}



- DISCAS Task Group used “Human Factors Ergonomics Society” standard, the 150-Rule, and acuity factor to facilitate objective guidance

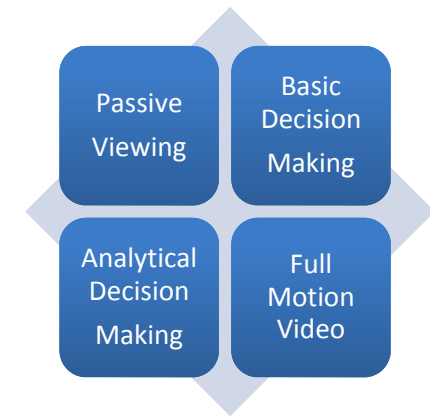

$$\text{Image Height} = \frac{\text{Farthest Viewing Distance}}{200 * \%Element}$$

$$\text{Farthest Viewing Distance} = \text{Image Height} * 200 * \%Element$$

What Is %Element?

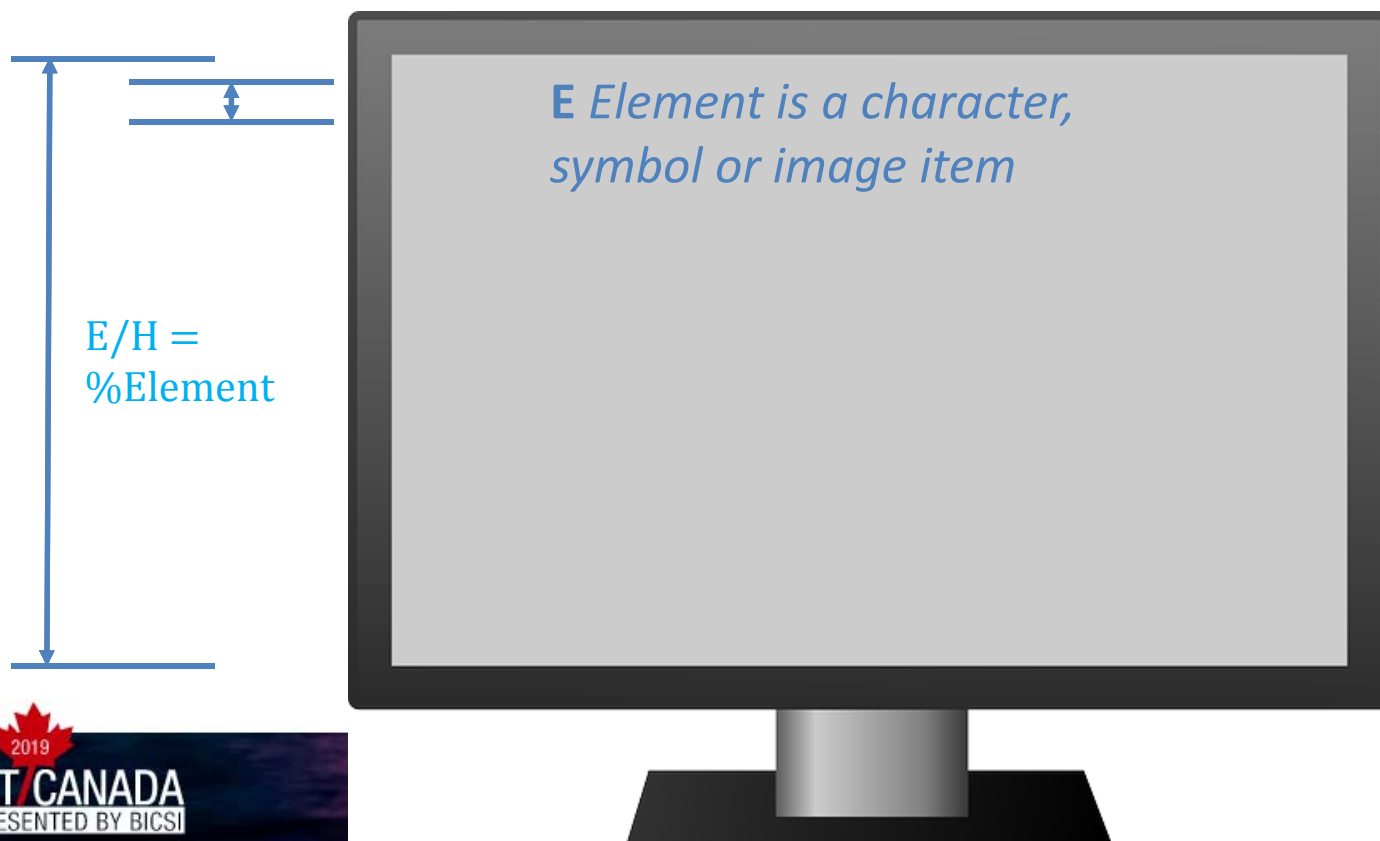

An Example of 2.5% Element

This is a 2.5 %E displayed on a 55-Inch LCD screen. This image was captured 8 feet from screen surface (4X screen height) and demonstrates legibility when the BDM is applied to a project.

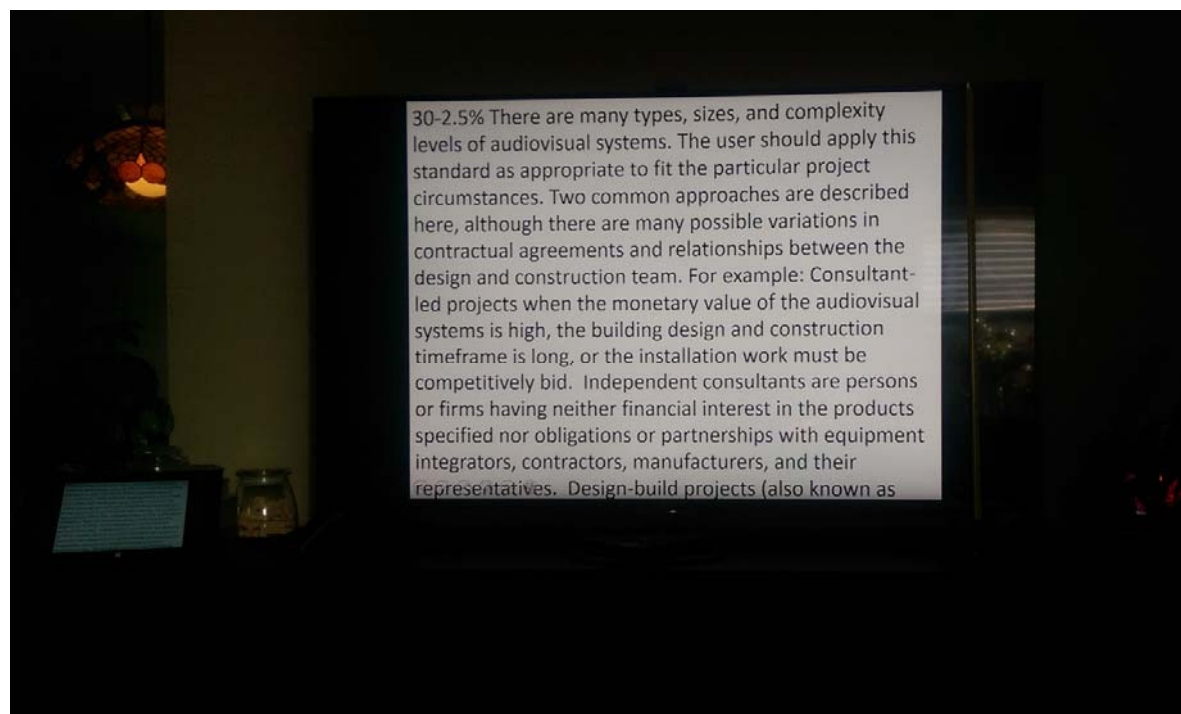

A Practical Example For Basic Decision Making

- A 75" 16:9 LCD display has an image height of 37"
- Using 2.0%Element, we calculate the farthest acceptable viewer distance at 12.3 feet
- Using 3%Element, we calculate the farthest viewer at 18.5 feet



Which display would you choose and why?

Three different image sizes:

- 42 inch (1054.3mm) for a 4% Element Height
- 56 inch (1405.7mm) for a 3% Element Height
- 84 inches (2108.5mm) for a 2% Element Height.

Sizes of the displays change, the physical size of a character: 1.68 inches (42.2mm)

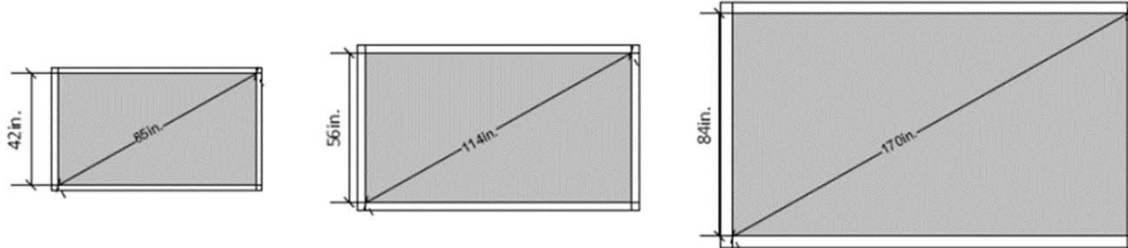

A/V Connection Methods

“Electricity is actually made up of extremely tiny particles called electrons, that you cannot see with the naked eye unless you have been drinking.” – Dave Barry

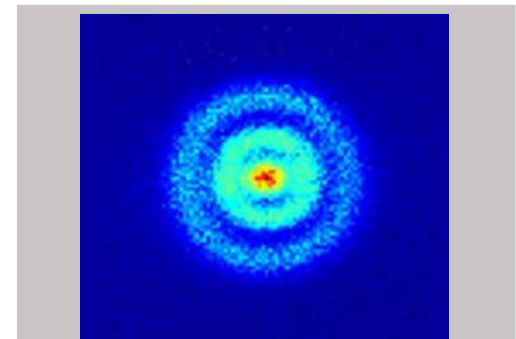

EDID

Hot Plug
Detect

plug
and
play

Voltage
Assertion

HDCP



ICT CANADA
PRESENTED BY BICSI

Bicsi

- Why Does This Matter?

- *Hot plug detect* is a signal that informs the source that a sink (display or load) is connected

- Source provides +5V to the sink, which the sink sends back to the source as an assertion voltage
- Repeaters and switchers may be required to pass a hot plug pulse to an upstream device

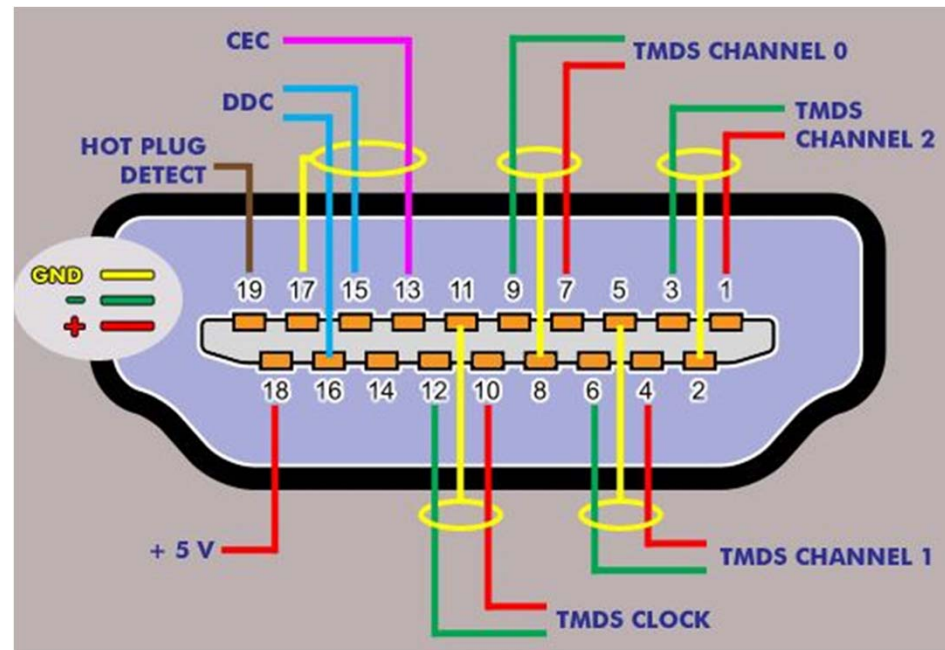

Voltage Drop Over Interconnect?



- HPD flows from the device to the display
- And then from the display *back* to the device

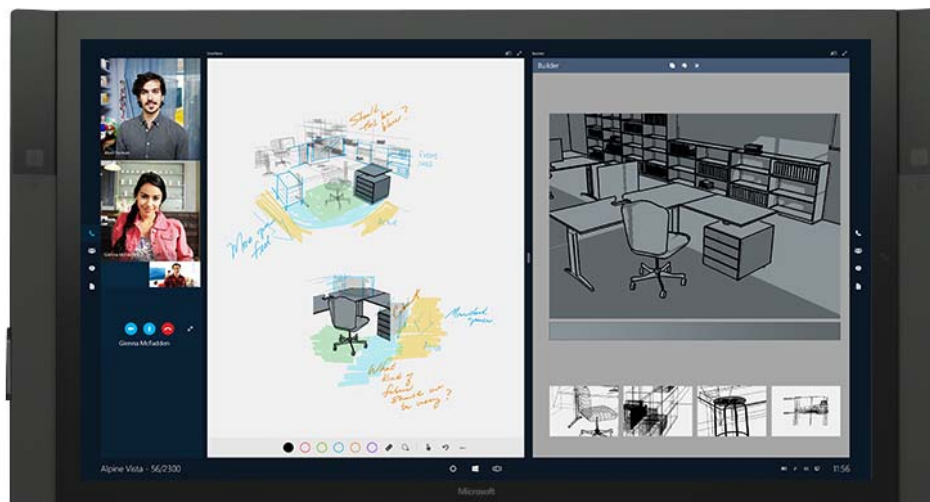

A Lot Could Go Wrong...

- Detecting proper voltages is the core of the hardware “handshake”
- When proper voltages are not present in a connected system...
 - Complete loss of picture – **Hot plug related**
 - Distorted video - **EDID related**
 - Flashing images - **HDCP related**



WHAT COULD GO
WRONG?

High Bandwidth Digital Content Protection

- HDCP 2.2 is designed to create a secure 4K content connection
 - Encryption on HDCP2.2 keys is more advanced
 - Includes “locality check” which requires $\leq 20\text{ms}$ latency source-to-sink
- HDCP 2.2 is not a firmware upgrade. This technology demands full hardware compatibility
 - All components in a system must support HDCP 2.2, including switchers, D/A, audio devices, etc.



HDMI 2.0 / HDCP 2.2
SUPPORT

A/V Connector Ecosystem

It can be helpful to envision physical layer A/V connectivity as wheels within wheels, with each successive layer encompassing more categories of connectivity and bridging longer distances. With each step up, bandwidth constraints become more challenging.

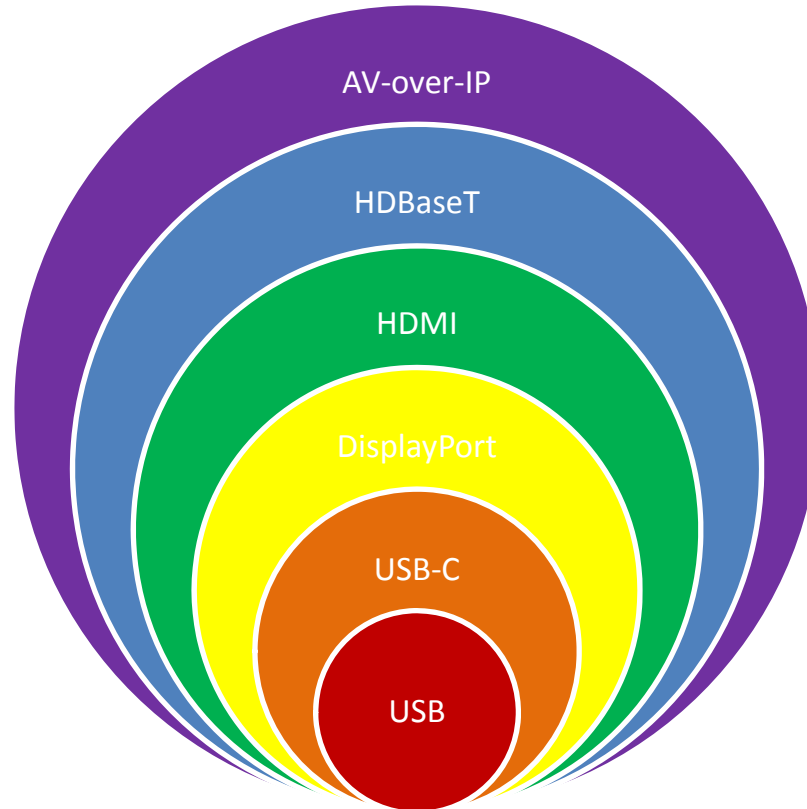



High Definition Multimedia Interface

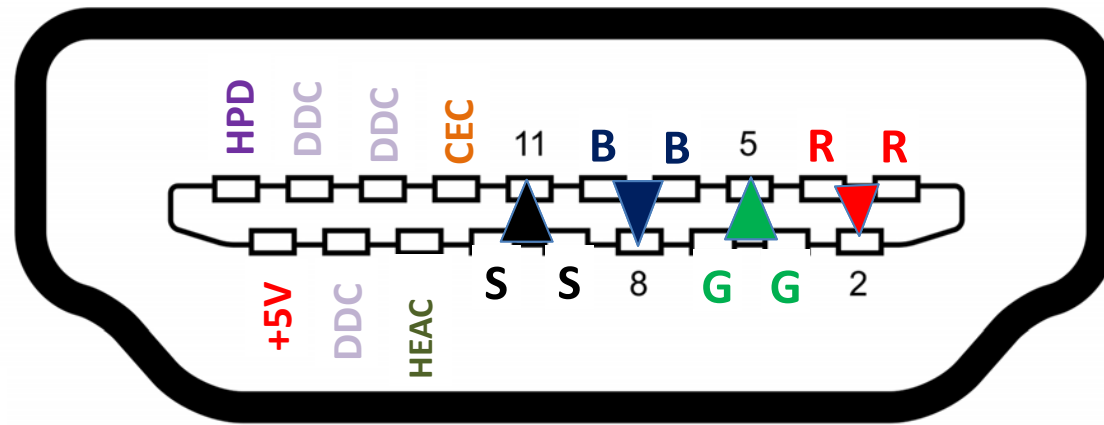

Parsing HDMI HPD Power

- HDMI specification requires all source devices to provide *greater than* 55mA on the HPD line
 - Located on Pin 18, must be 4.7 to 5.3V
 - 55mA is not enough current to operate most HDMI accessory devices, *but in common practice most source devices provide more current on the 5V line than the HDMI specification requires*
 - Design considerations should be based on specification, not “common practice”
- HDMI provides +5V to the sink, which the sink sends back as the hot plug assertion voltage on pin 19



Active HDMI Over Copper

- Directional, active cables that incorporate a chip set to pre-equalize the signal so that it maintains eye pattern fidelity
 - Bus powered solution – no external power supply option.
 - Chipset is embedded at the sink connection
- “Stacking” an active, embedded chip with an external bus-powered device (a switch, for example) may cause system instability



HDMI Embedded Media Converters

- An embedded media converter is a chip that changes the signal to leverage a completely different optical or electrical connection topology
 - Some examples include RapidRun Optical, AOC, Celerity Optical Gateway
- Often these systems will leverage a USB power connection
 - When copper is not co-run with the optical channel, the power must be sourced at both the source and sink
 - However, the transmitter function may be powered by the HDMI or DisplayPort bus



Can this be fixed?

- Many installation failures associated with sagging power and/or under-current situations can be addressed with a voltage inserter
 - However, multiple breaks in HDMI connection can induce distortion in the eye pattern. It's important to analyze connection segment lengths.





DisplayPort

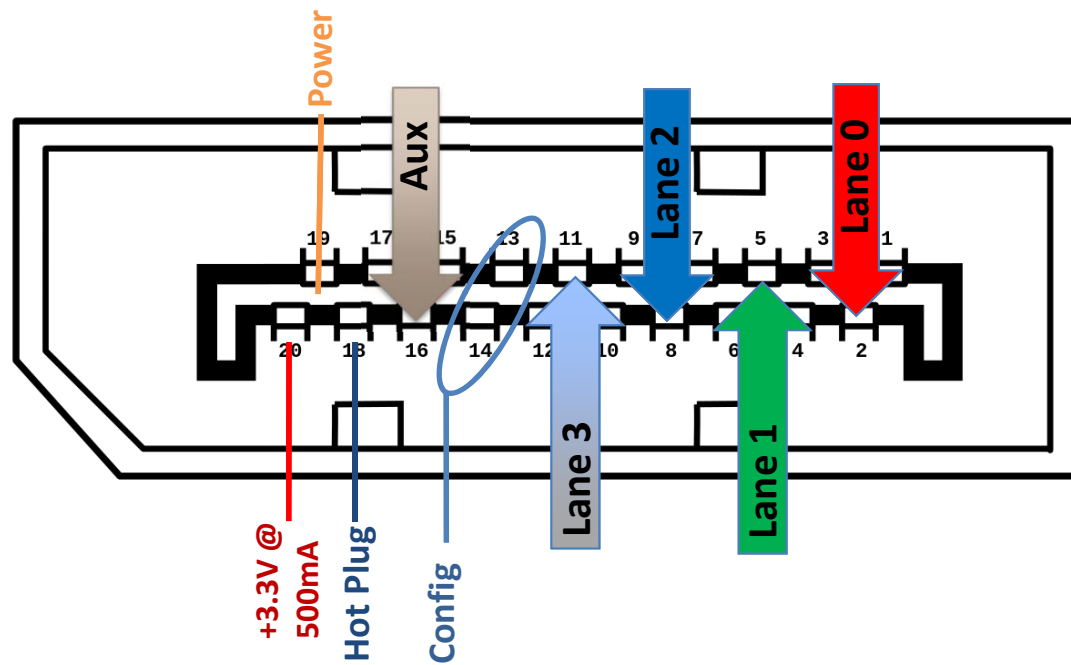

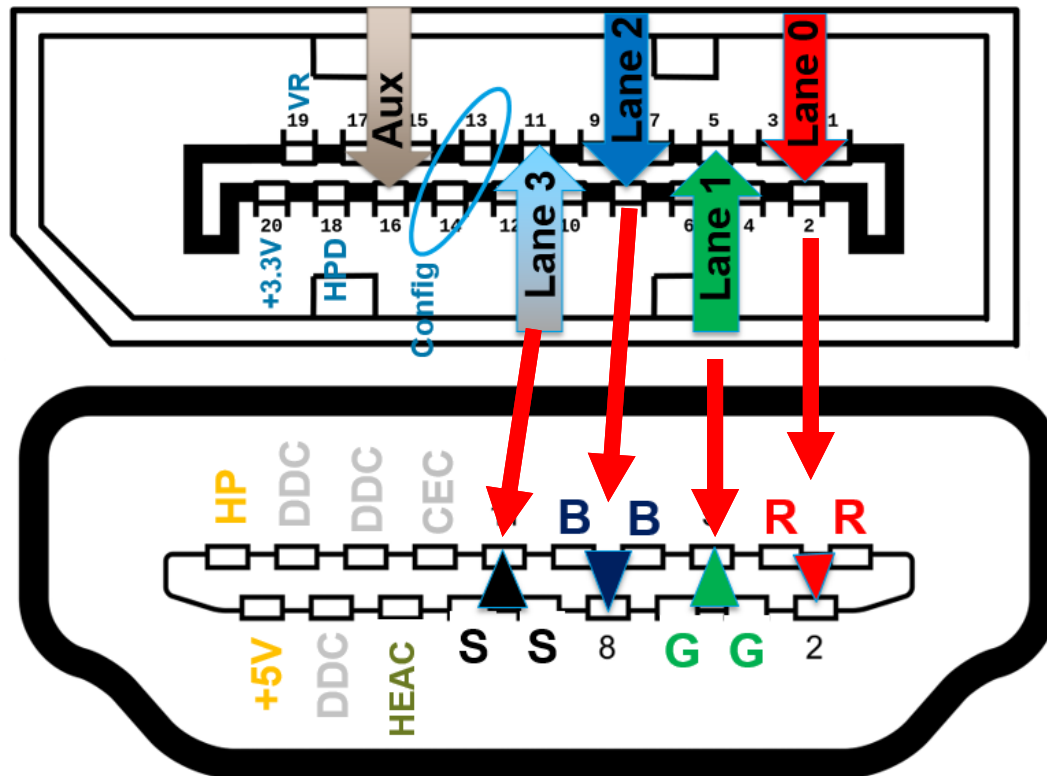

The difference between DP1.2a Standard and the DP++ option is the ability of the later to “speak” to an HDMI display without the need for active circuitry

Interface Using Dual-mode adapter

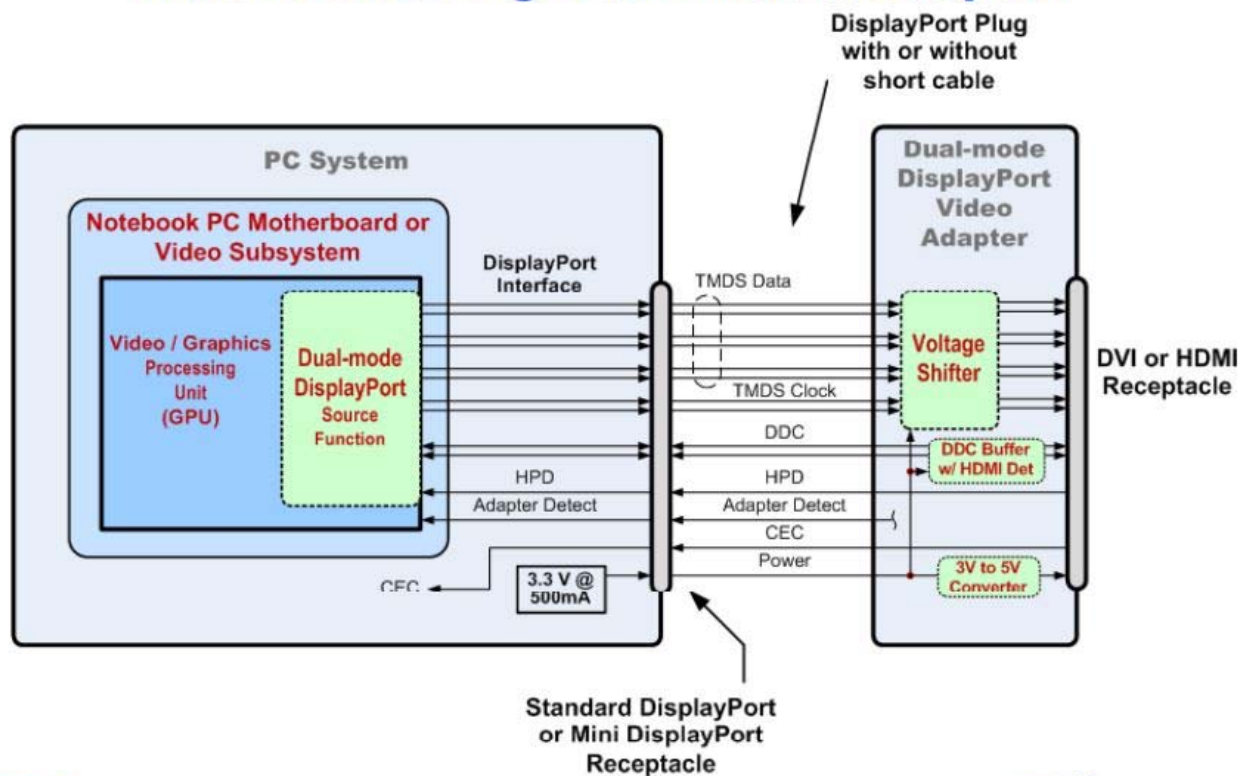

Potential DisplayPort Issues

- DisplayPort exhibits similar potential for Hot Plug Detect or DDC/EDID failure as other connection standards
- DisplayPort to VGA adapters include a D/A chip set
 - Chip set requires power to operate and this may affect battery life and/or link length

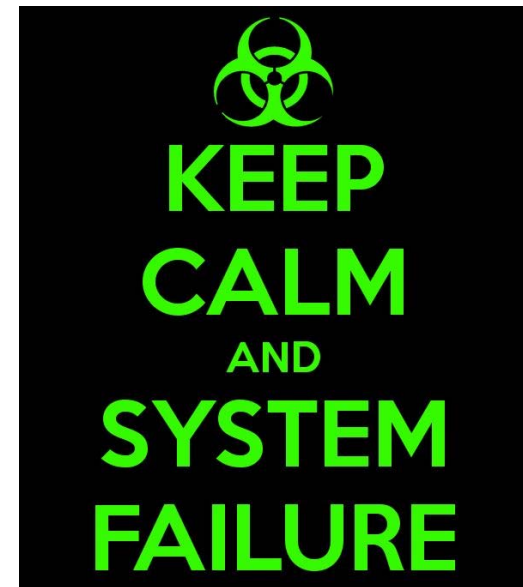



- USB operates on a strict hierarchy of 7 tiers
 - All functions occupy layer 7
 - Tiers 2-6 are reserved for hubs only.
 - Extenders are almost always seen as Hubs

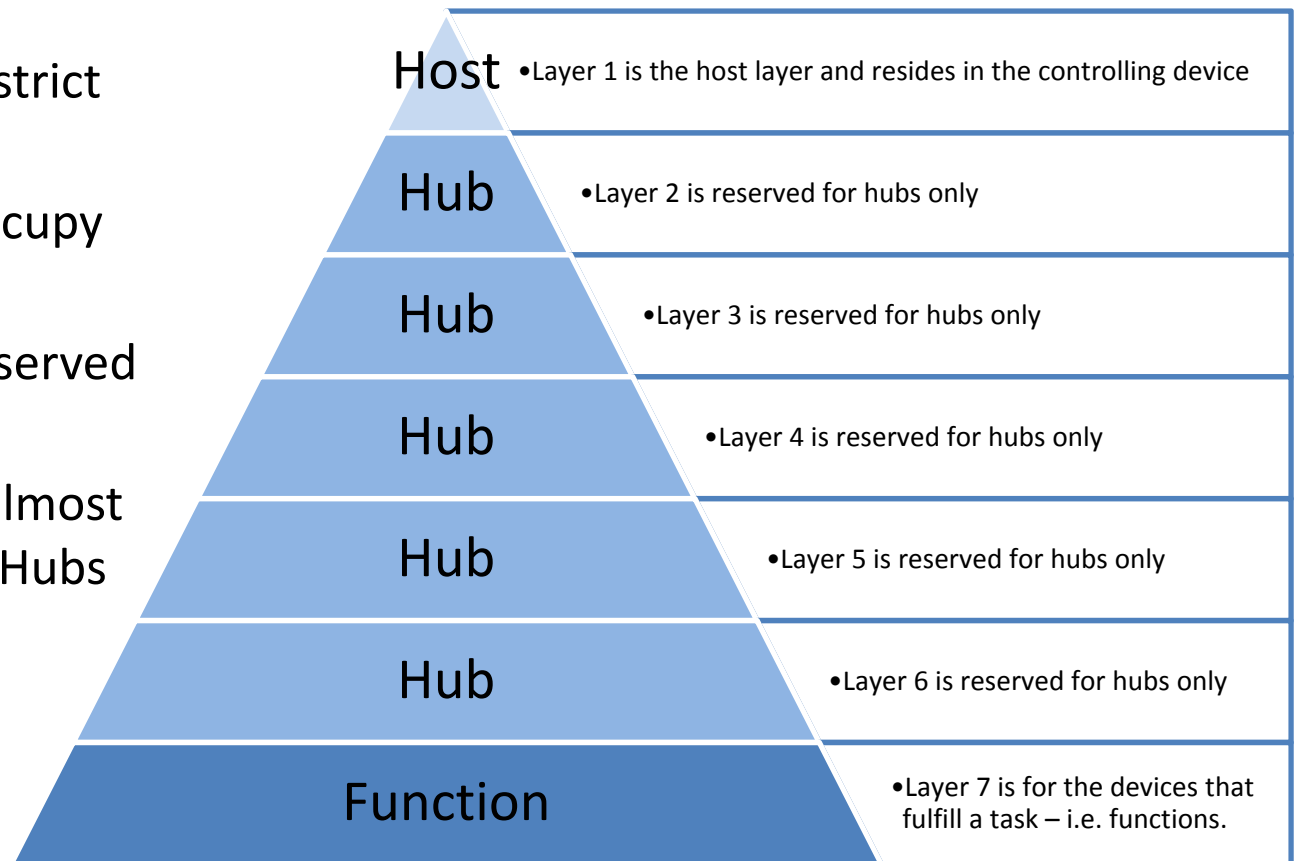

- Hubs have three functions
 - Repeater - connects and releases functions
 - Controller - communicates with the host
 - Transaction translator – controls speeds
- Hubs may be bus-powered or mains-powered



Example of a 7-Port Hub

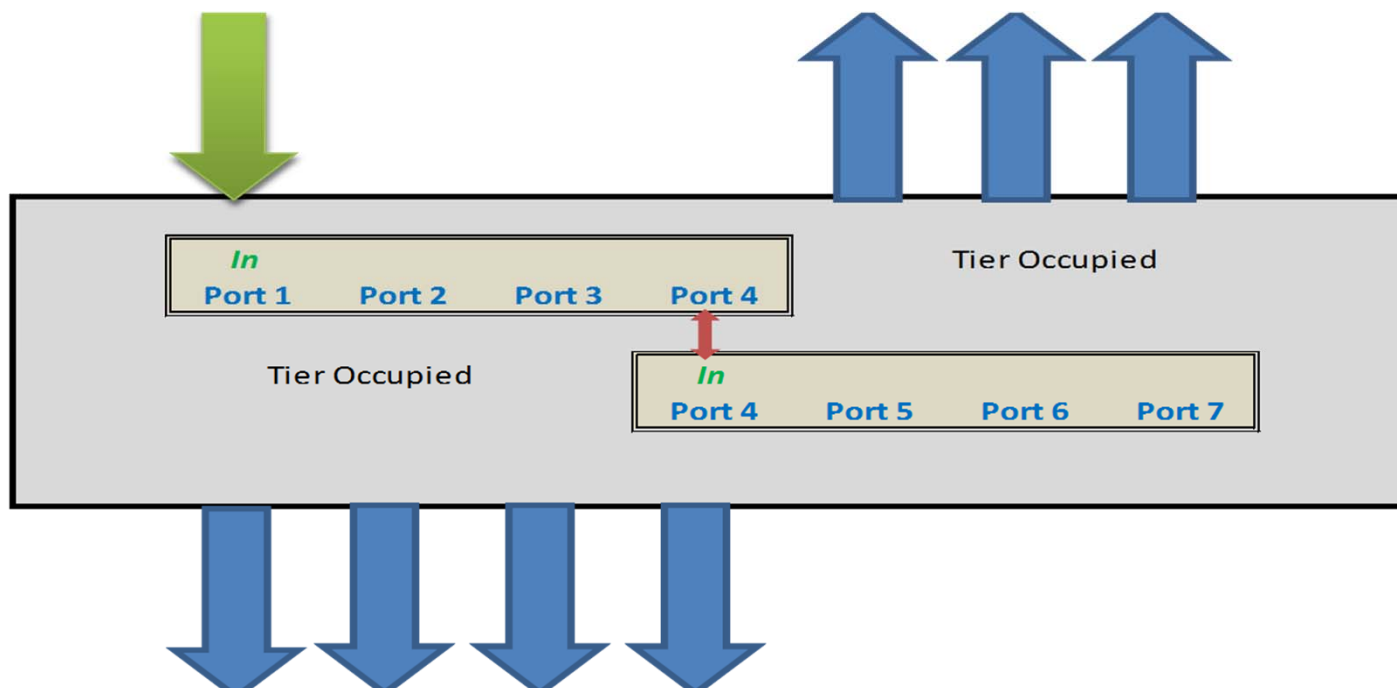

Power In The USB Environment

- USB specifies 5 V (+/-5%)
- Power is delivered in quanta of unit loads
- A single unit load is 100mA for USB 1.1 & 2.0, 150mA for USB 3.0
- Low-power devices draw 1 unit load
- High-power devices may draw up to the maximum number of unit loads permitted after negotiation



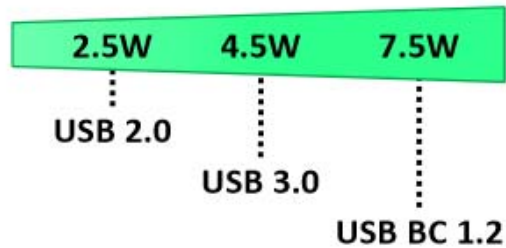

Broad international adoption of USB Battery Charging standard for mobile devices



- China, Europe drove standardization as a means to increase charger reuse and reduce electronic waste

Agreement reached on Micro-USB connector and the standard for the common mobile charger

CENELEC and the USB Implementers Forum reach agreement on memorandum of understanding

BRUSSELS – March 1, 2011– A Memorandum of Understanding (MoU) was signed today between the USB-IF and CENELEC, the European Committee for Electrotechnical Standardization.

A Closer Look At BC 1.2

- Negotiation of power capability is performed on USB 2.0 D+/D- before standard USB enumeration and requests. Ports are categorized into 1 of 3 possible configurations
 - **Standard Downstream Port (SDP):** 500mA with USB 2.0 data, describes a typical USB port
 - **Dedicated Charging Port (DCP):** 1.5A or beyond with no USB 2.0. This kind of port is typically found as a wall adapter or mobile charger
 - **Charging Downstream Port (CDP):** Supports high current and USB 2.0. Typically a port specifically labeled for fast charging by the PC/Laptop manufacturer.



Extender Systems

- Extenders typically occupy a tier – they are seen by the host as a hub
- SuperBooster systems are powerful components of a USB network design



Extension Techniques

- **Equalization based**
 - Limited to short distances, typically around 10 meters
- **Emulation based**
 - Achieving interoperability is difficult
- **Protocol conversion based**
 - Complex implementation
 - Icron's ExtremeUSB® extension technology is based upon protocol conversion and can extend up to 10km



Video over USB – DisplayLink

- USB 3.1 Gen 1 allows USB-to-video converters from DisplayLink to support up to 5Kp60 (5120x2880) over DP interfaces (4K UHD over HDMI) interfaces
 - Typically found in docking stations or Unified Communication equipment



USB 3.1 Gen 1 and Gen 2

- In 2013, USB-IF introduced USB 3.1, also known as SuperSpeed+
- There are differences in Gen1 & Gen2 at Phy, Data and Protocol layer
- **Remember This:**
 - **USB 3.1 Gen 1 = USB 3.0 = SuperSpeed = 5 Gbps**
 - **USB 3.1 Gen 2 = SuperSpeed+ = 10 Gbps**



USB Type-C

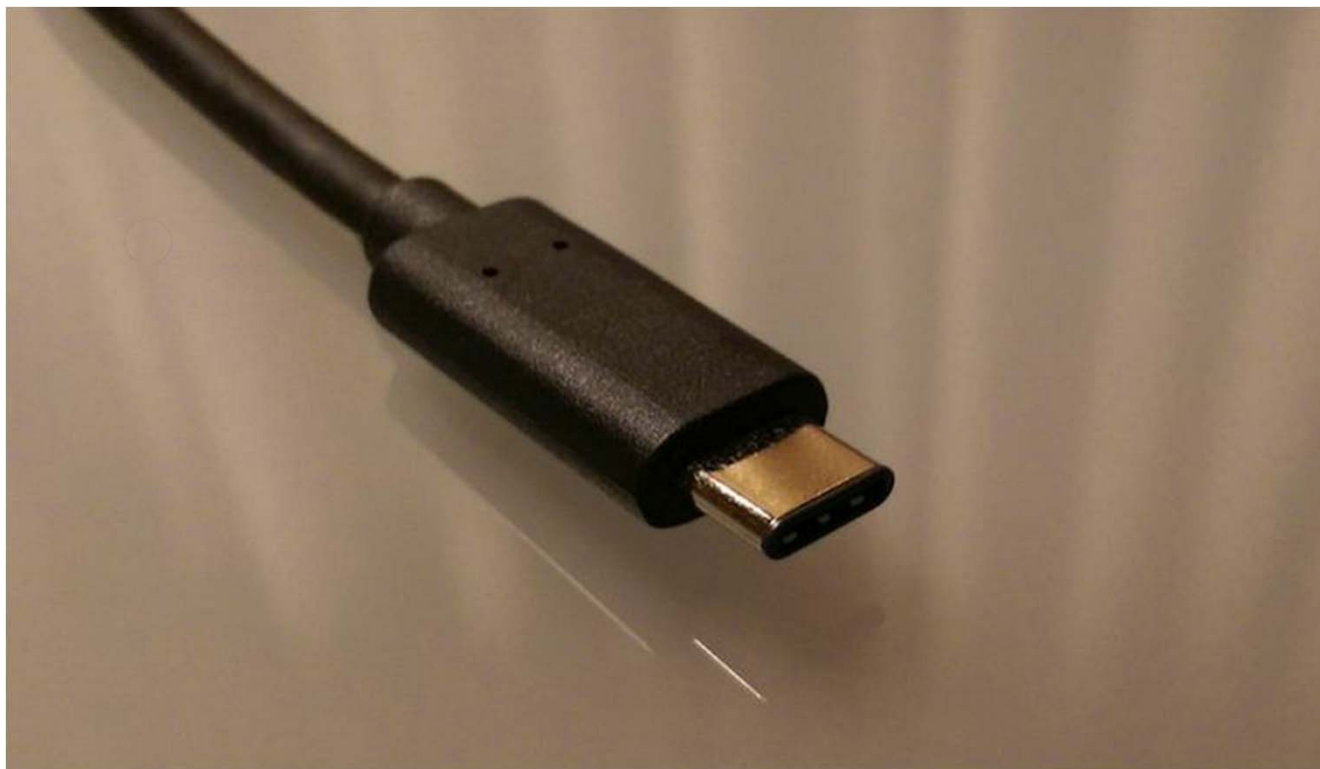



Type-C to Type-B

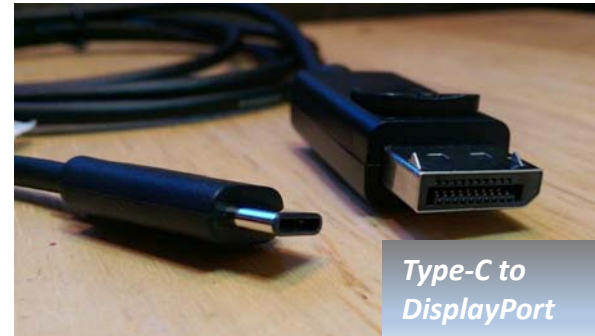

Type-C to DisplayPort



Type-C to Micro-B



Type-C to Type-A

So What Is Type-C?



Apple, Google, Microsoft...



What Does It Do?

USB Host or Device with DisplayPort Alternate Mode Capability.

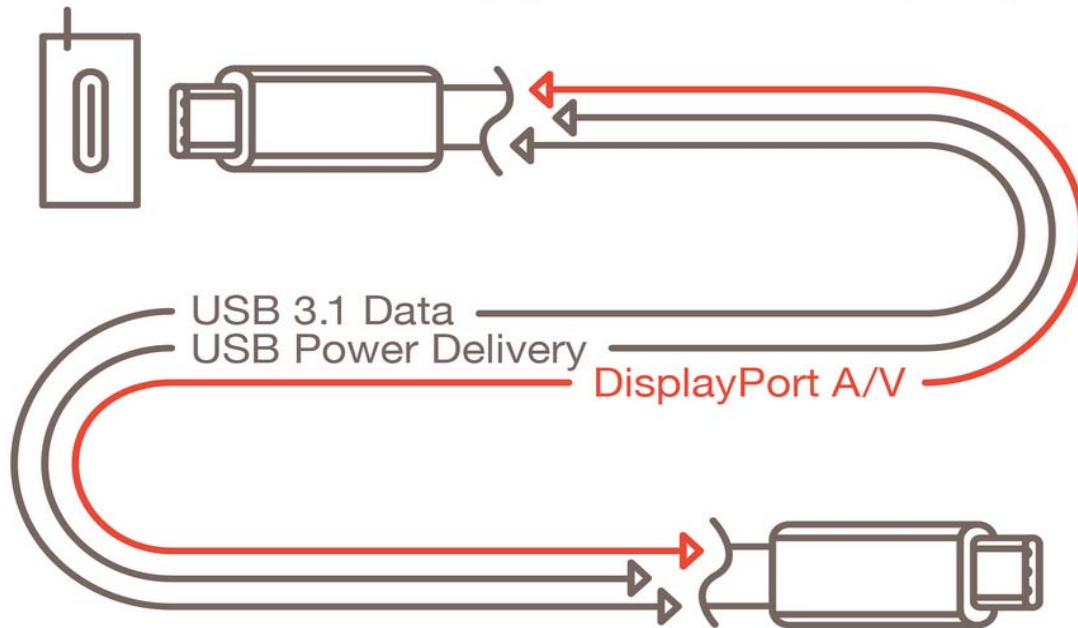

USB Type-C to Type-C Cable.

High Speed Data Path (TX for USB, or for DP Alt Mode)

USB 2.0 Interface

High Speed Data Path (RX for USB, or TX for DP Alt Mode)

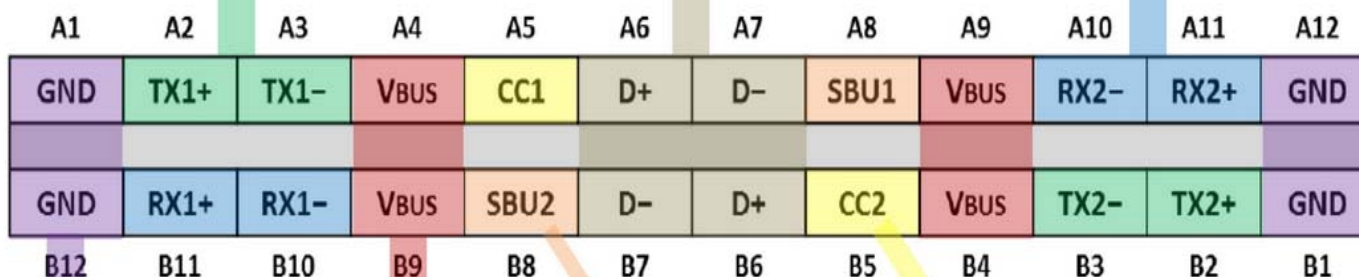

Cable Ground

Cable Bus Power

For Sideband Use (not used for USB)

Plug Configuration Detection

- One becomes V_{CONN} , for cable or adaptor power
- CC is used for USB-PD communication

Type-C Modes

- Type-C Alternate Mode can support USB, DisplayPort, Thunderbolt 3, SuperMHL and HDMI through “Alternate” Modes
 - Supports up to 4Kp60 4:4:4 with DP 1.2a/1.3/1.4
 - Simultaneous Support for USB 3.1 Gen 2 serial connections
 - Simultaneous Support for power transfer up to 100W
 - USB 2 remains available in all configurations
- *Understanding the relationship between DisplayPort and HDMI is vital to properly deploying emerging USB-C solutions!*

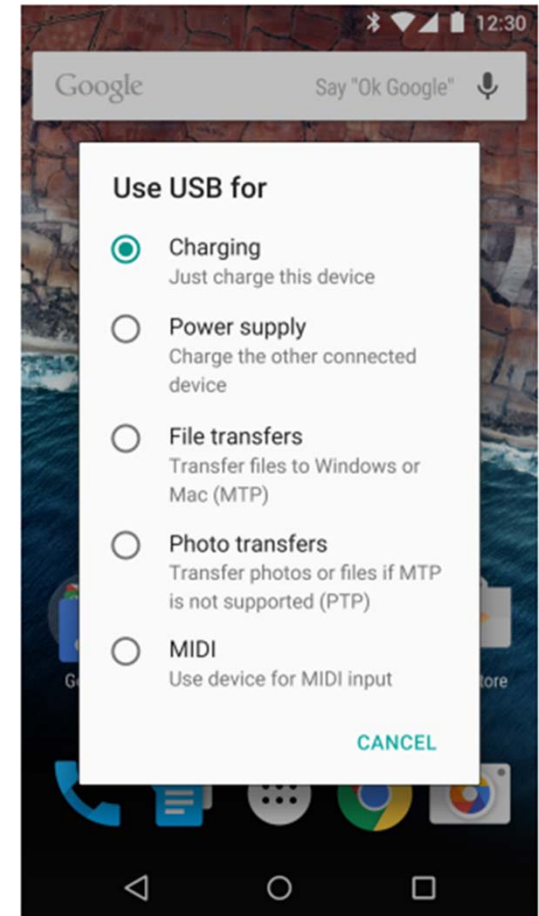

USB Type-C Leverages DP 1.2a

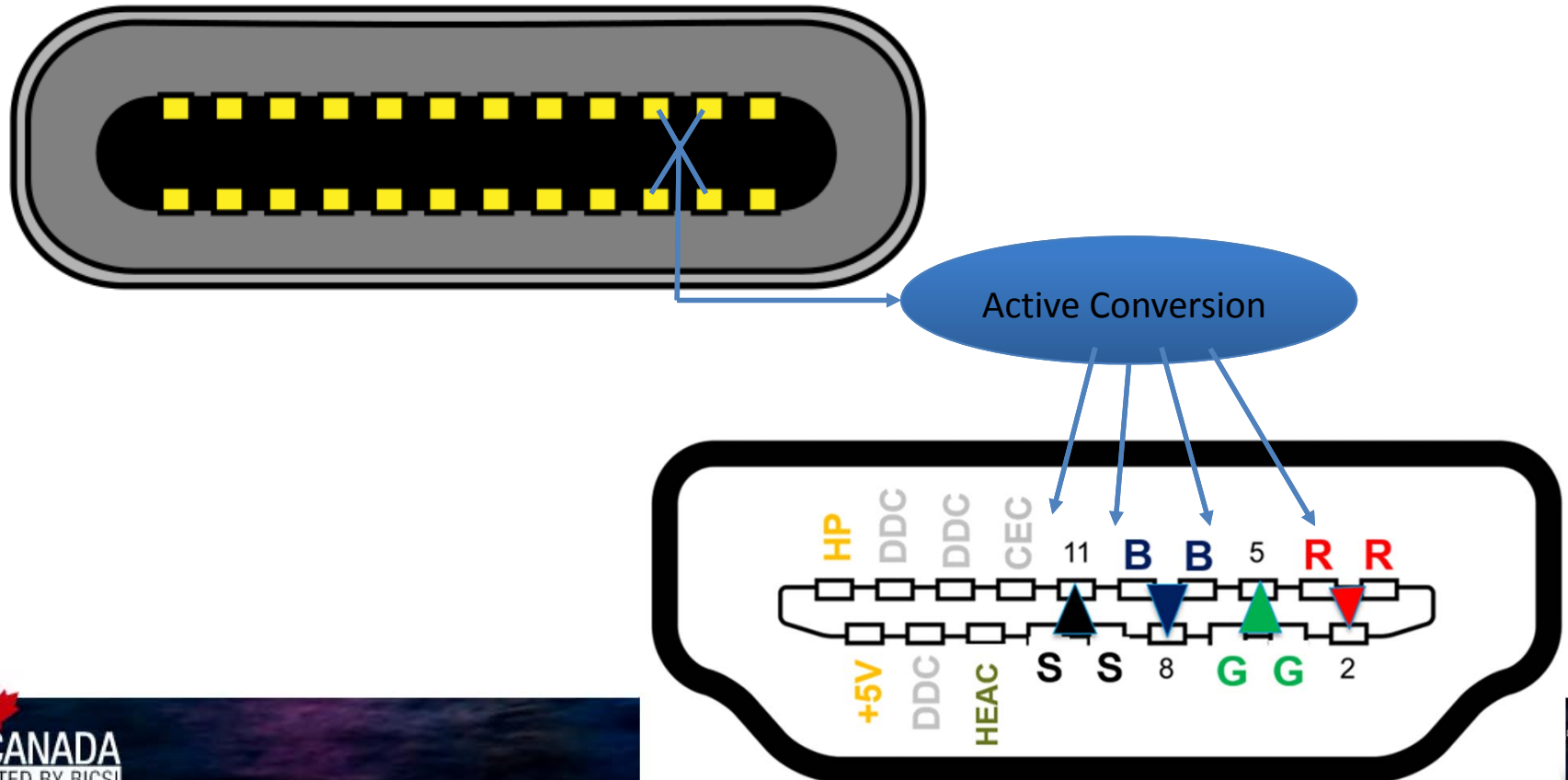

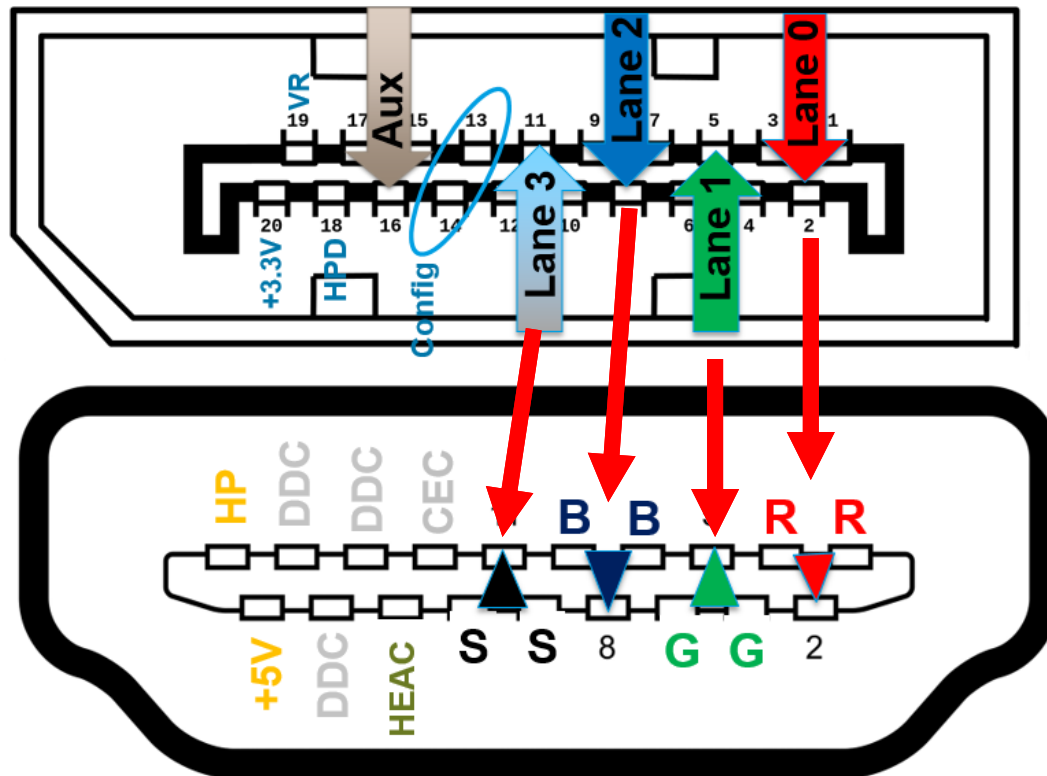

The difference between DP1.2a Standard and the DP++ option is the ability of the later to “speak” to an HDMI display without the need for active circuitry

USB Power Delivery Profiles

PDP (W)	Current at 5V (A)	Current at 9V (A)	Current at 15V (A)	Current at 20V (A)
$0.5 \leq x \leq 15$	$x \div 5$			
$15 < x \leq 27$	3	$x \div 9$		
$27 < x \leq 45$	3	3	$x \div 15$	
$45 < x \leq 60$	3	3	3	$x \div 20$
$60 < x \leq 100$	3	3	3	$x \div 20^1$

¹ Requires a 5A cable.

- Sources & Sinks must claim their capable Power Delivery Power (PDP)
- Based on PDP, various voltage levels are available
- Sources and Sinks negotiate voltage levels compatible at the appropriate PDP

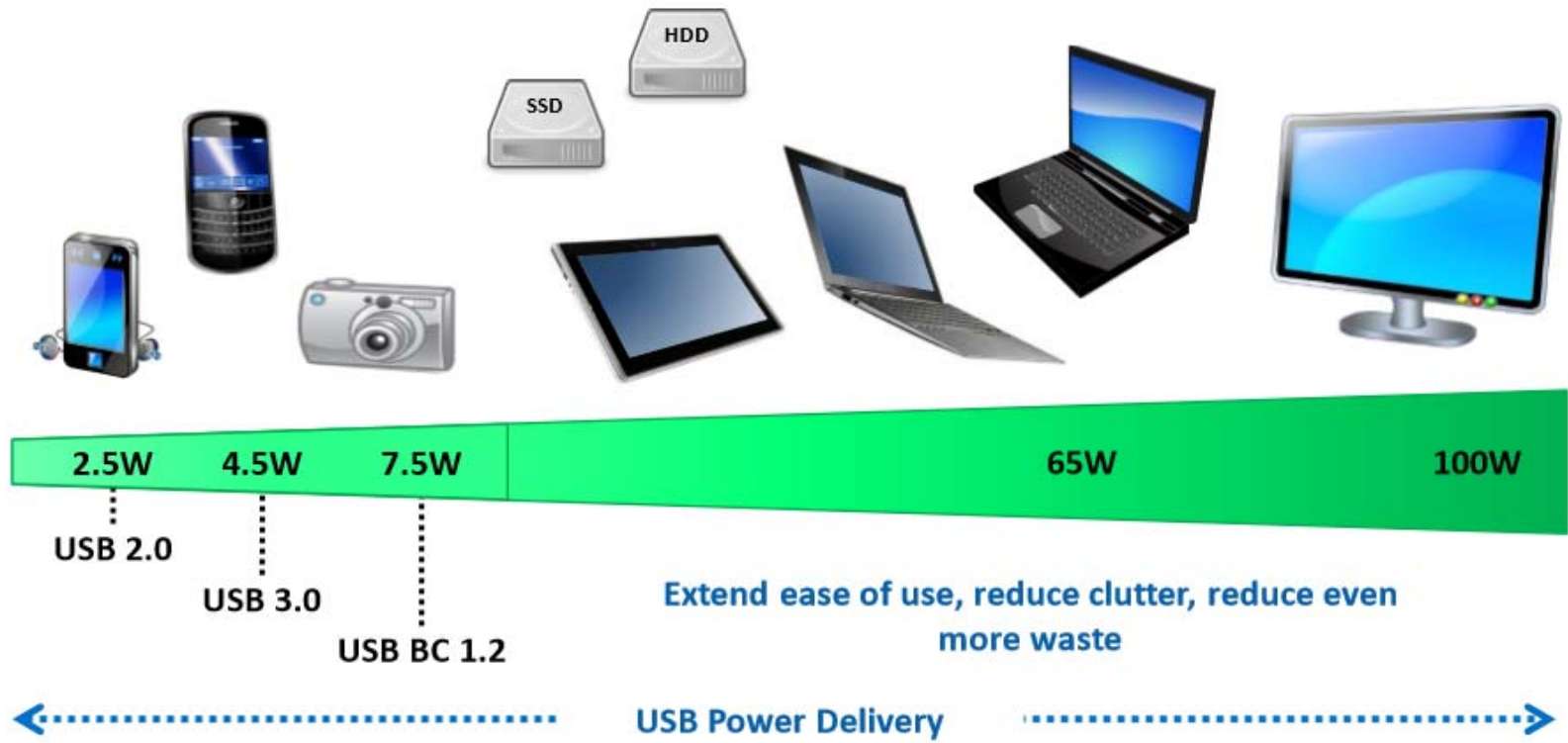

E-Markers and Billboards



- EMCA stands for the Electronically Marked Cable Assembly
- E-marking/EMCA is required under the following conditions:
 - USB-C cable is required to support more than 3A current (more than default)
 - USB-C cable is a full featured cable, supports either USB 3.1 Gen1 or USB 3.1 Gen2 signaling
- USB-C cable malfunction prevention
 - Authentication

USB 3.1 Gen 1 and Gen 2 Challenges

- USB 3.0 cable length is typically limited to 3m
- Three main contributing factors to signal degradation:
 - Insertion Loss
 - Cross Talk
 - Reflections



3 meters

Extra distance



Type-C Extension

- Protocol Conversion To 10GE
 - No timing or compatibility issues associated with Emulator solutions
 - Distribution & switching achieved with off the shelf switches
 - Proper VBUS handling to ensure stable reliable connections
 - Power Delivery Negotiation with POE switches



Summary of Features

- USB 3.1 Gen 1 data rate up to 5 Gbps
- Supports all USB 3.1, 2.0, 1.1 devices simultaneously at full bandwidth
- Four available 3.1 Gen 1 ports
- 100/1000 Ethernet channel; LAN pass-through
- Single cable, CAT 6a up to 100m
- Point-to-point connection



HDBaseT 5Play™

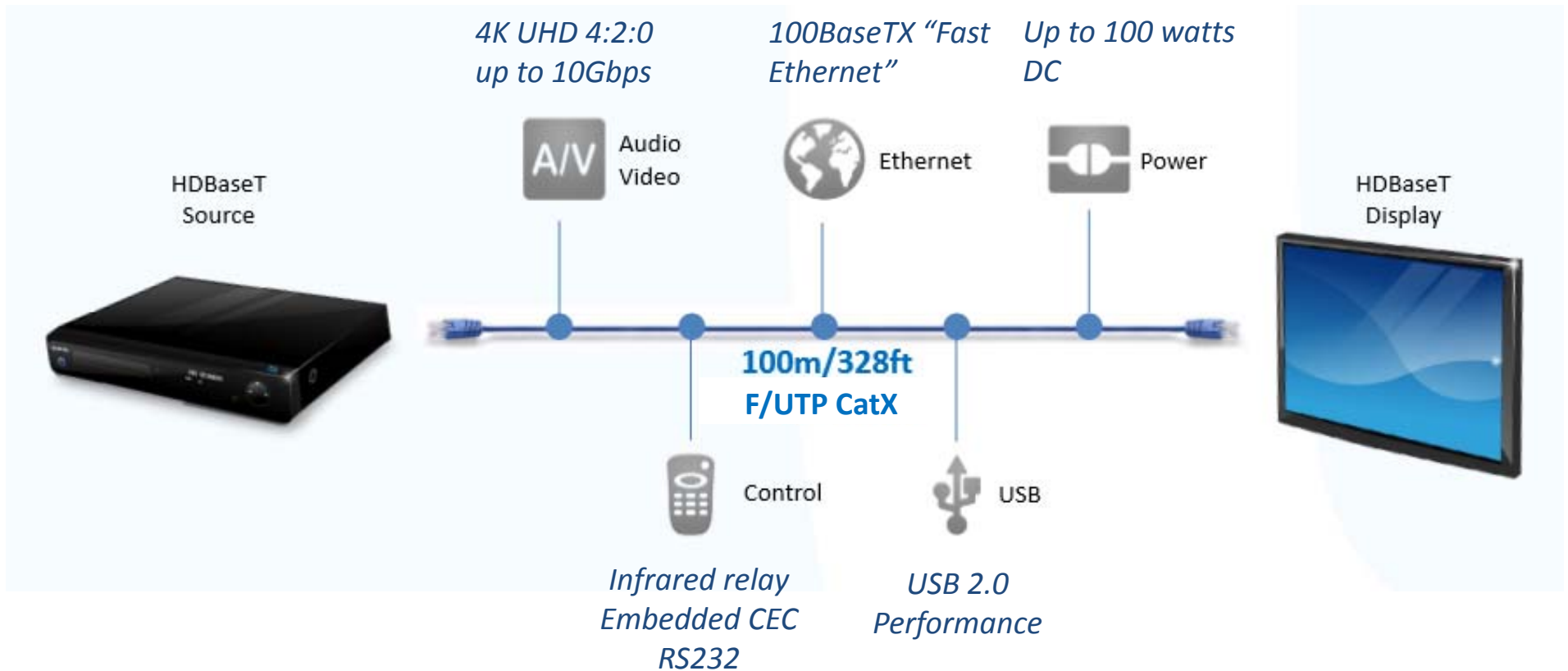

HDBaseT Interoperability



- Interoperability is defined as the ability of systems and equipment to work together.
 - Products can be interoperable for some features and not for others
 - Certification only ensures compliance to the HDBaseT standard
- First check at http://hdbaset.org/products_list
- Then verify whether products support the same features
- Check Mfr recommendations
- *POC is a pretty good idea!*

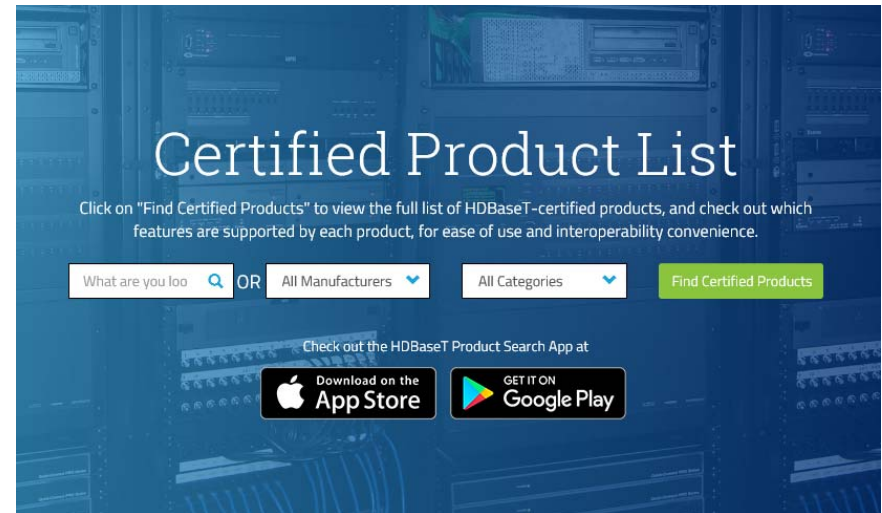

- 1 **HDBT** Logo.....
- 2 Certified List.....
- 3 Vendor's Collaterals.....

*What payload does HDBaseT
actually send through the wire?*

Symbol, Baud, Modulation & Bitrate

- When the transmission medium's *bit-rate* isn't sufficient for the baseband signal, modulation schemes are used
- Symbol rate, also known as baud rate, is the number of *symbol changes* per second
 - Each symbol can represent several bits of data, the raw rate of transfer is called bit-rate
 - Symbol rate allows data transfer \geq bit-rate
 - 1,000 baud = 1,000 symbols per second
 - Each symbol can represent a different step on a binary scale
 - Example: a system using 2 bits per symbol doubles the effective bit rate, 1000 baud = 2000 bits

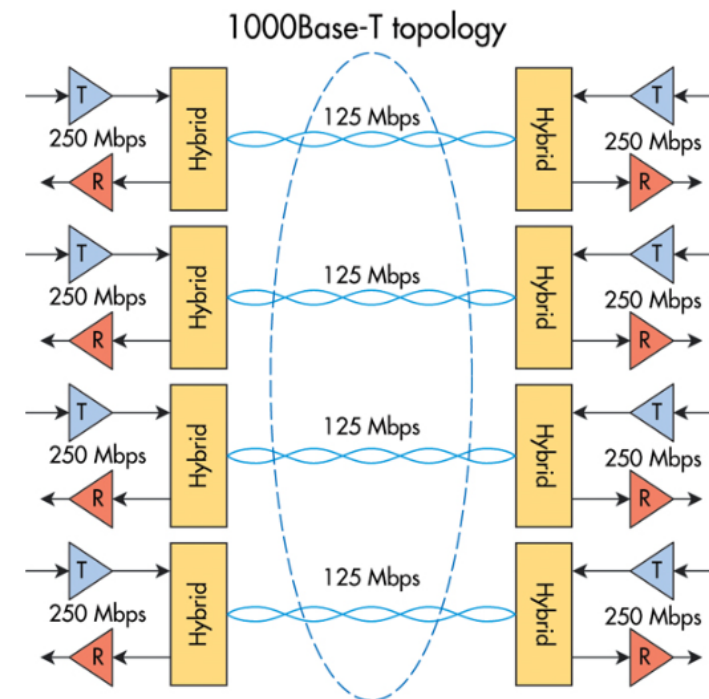

This is the physical configuration (PHY) of 1000BaseT with a bit rate of 125 Mbps.

Gigabit Ethernet Uses PAM-5

- 1000Base-T uses PAM5 encoding, where each transmitted symbol represents one of five levels: $-2, -1, 0, +1, +2$
 - Four levels represent two bits; the fifth level supports forward error correction (FEC)
 - As the number of levels increases, susceptibility to noise increases proportionately
- Broadcast digital television (ATSC) 8VSB uses Pam-3, 32Mbit/s over 6MHz channel
- 10GBase-T, 25GBase-T and 50GBase-T use a far more demanding PAM-16 scheme

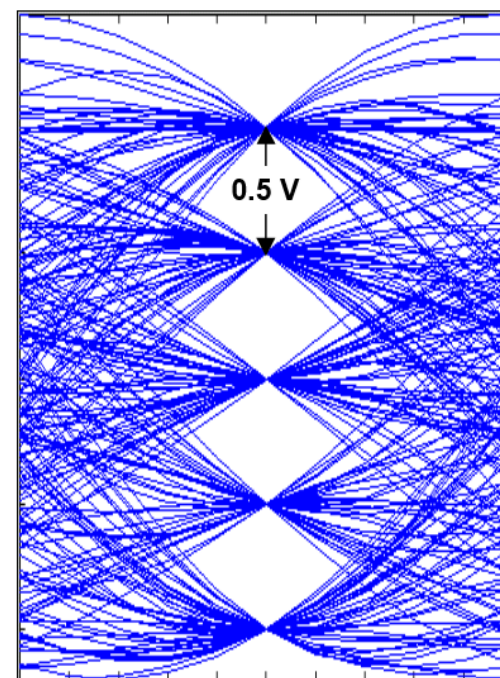

HDBaseT Uses PAM-16

HDBaseT uses PAM16 - each symbol is transmitted using one of 16 discrete, differential voltage levels = 2^4 symbols

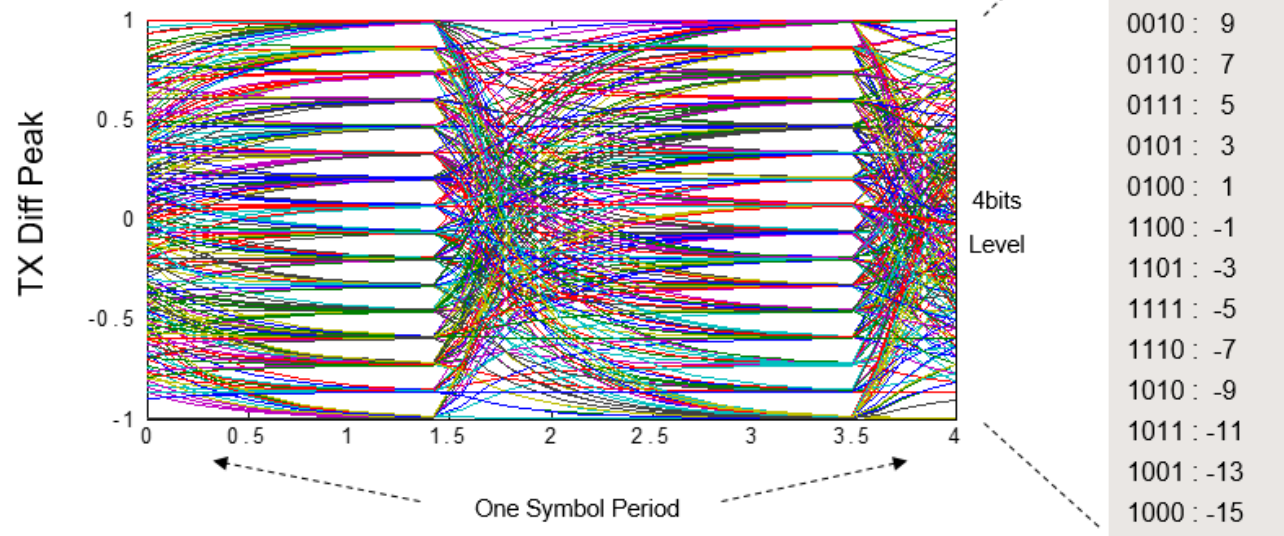

PAM16 TX Eye Pattern

Physical Layer Considerations

- Near End Crosstalk (NEXT)
 - EMI Crosstalk from one pair to another pair
 - Expressed in dB/ft or dB/1000ft
- Far End Crosstalk (FEXT)
 - Interference between two pairs measured at the far end with respect to the interfering transmitter
- Alien Crosstalk (AXT)
 - Interference caused by other cables routed close to the cable of interest

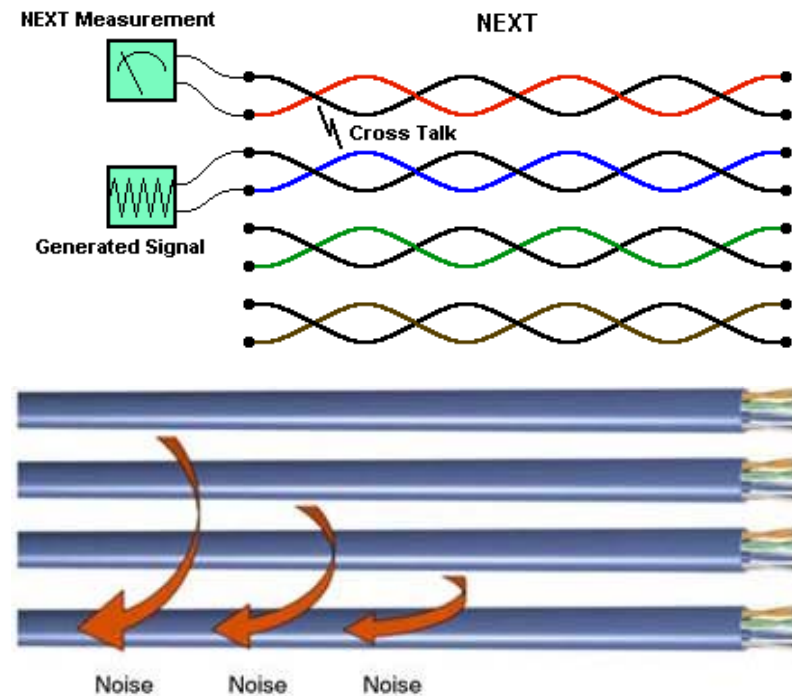

Example of Cat6 F/UTP

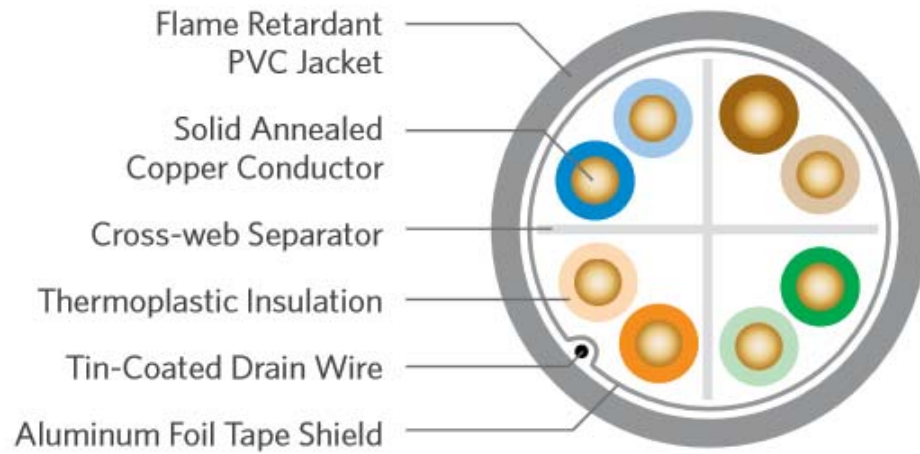

SPECIFICATIONS	
Configuration	Copper pairs surrounded by aluminum PET foil with an outer drain wire and jacket
Pair Count	4
Conductor	Solid annealed copper
AWG (mm)	23 (0.57)
Insulation	CMR: Thermoplastic CMP: FEP
Insulation Colors	Pair 1: ColorTip Light Blue, Blue Pair 2: ColorTip Light Orange, Orange Pair 3: ColorTip Light Green, Green Pair 4: ColorTip Light Brown, Brown
Separator	Cross-web
Shield	Aluminum/PET with 10% overlap
Drain Wire	Tinned copper
Jacket	CMR: Flame retardant (FR) PVC CMP: FR, low smoke PVC
Characteristic Impedance Ohms	100 ± 15
Nominal Velocity of Propagation %	CMR: 66 CMP: 71

Example – HDBaseT Certified
Superior Essex 6T-246-3A

Non-Continuous Shielding

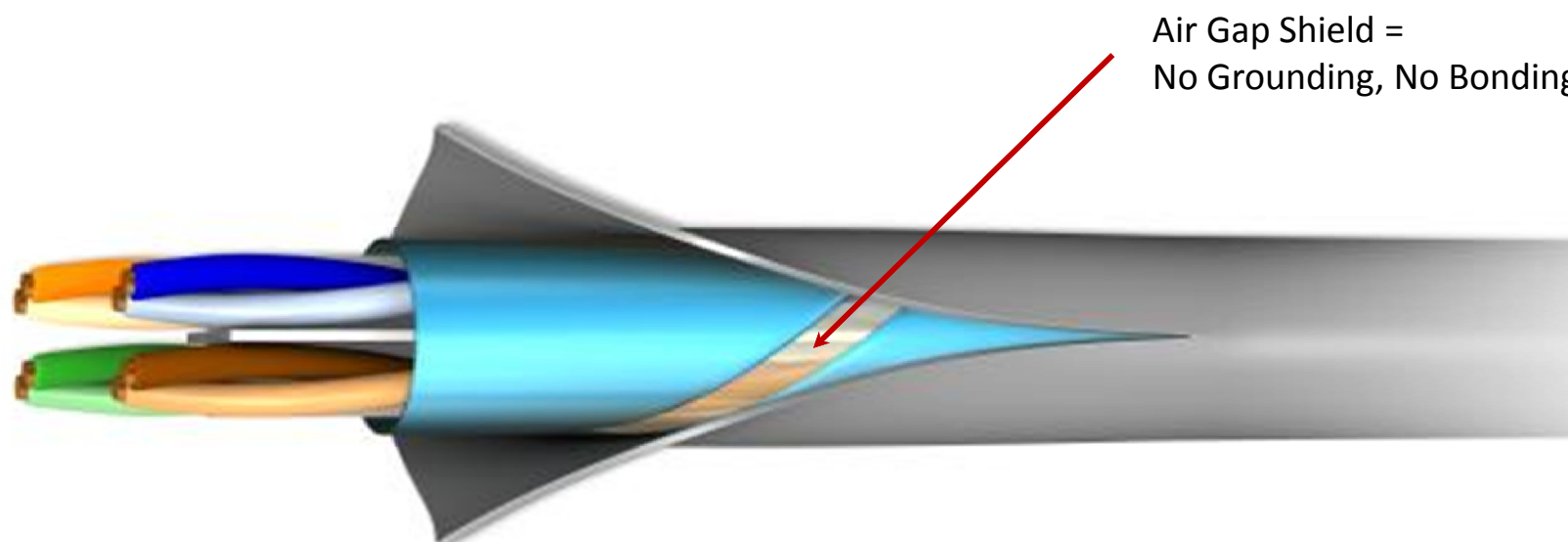

Segmented shield can provide protection similar to continuous shield

Example – HDBaseT Certified Superior Essex Category 10Gain® XP CAT 6A U/UTP

Understanding AV-over-IP



Why AV-over-IP?

- AV started simple, connecting video to monitors and bandwidth was not an issue
- Then, as we wanted more connections, matrix switches appeared (even 128x128!)
- Digital video came along, EDID and HDCP had to be handled and the hardware become more complex
- A consumer connector HDMI was forced upon the pro-AV world
- Now we have 4K/UHD, HDCP 2.2, clock rates to 600 MHz or more, HDMI 2.1
- Oh, and essentially **no standards**, so each solution has a name and does not play well with other solutions.



DVI 
 Display Port
 HDMI

Point to point



Displays



AV Sources



Point to point

4 twisted pair cable up to 100 mts



Why AV-over-IP?

- **Standards** that guarantee product compatibility and interoperability
- **Networks** that have been operating for years, are continuously being upgraded (bandwidth and performance)
- **Cabling** options that include Category as well as fiber cables that allow enhanced bandwidth and distances
- **Switches** can send anything anywhere, and to many places at the same time (multicast).
 - 10G coming down in price as 4K and 8K arrive.

Why AV-over-IP?

AV Source
Display Port
HDMI
Control Sources
RS232
USB
IR



“Heavy” Compression
(Lossy)



Switch 10G, 24 ports



“Light” Compression
(Visually Lossless)



AV-over-IP

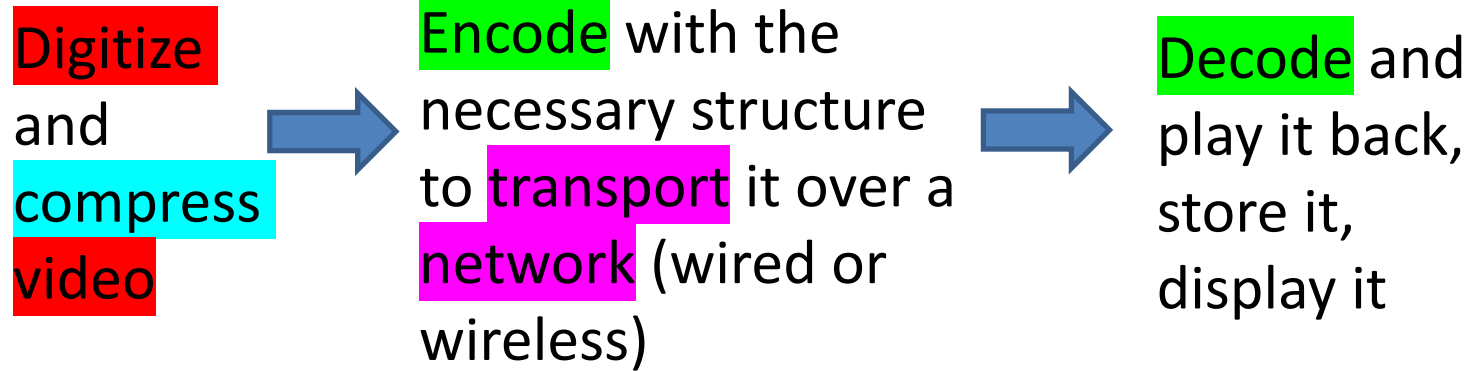

Digital Video Concepts
Chroma Subsampling

Compression Codecs
TCP/IP networking protocols

Compression Codecs

Compression



Compression

- *Spatial (or intraframe)* compression takes place on each individual frame of the video, compressing the pixel information as though it were a still image.
- *Temporal (or interframe)* compression happens over a series of frames and takes advantage of areas of the image that remain unchanged from frame to frame, throwing out data for repeated pixels.
 - Temporal compression relies on the placement of *key frames* interspersed throughout the frames sequence. The key frames are used as masters against which the following frames (called delta frames) are compared. It is recommended that a key frame be placed once every second; therefore, if you have a frame rate of 15 fps, set your key frame rate once every 15 frames.

Interframe Compression

These sections are identical



New image content

A Brief History of Video Codes

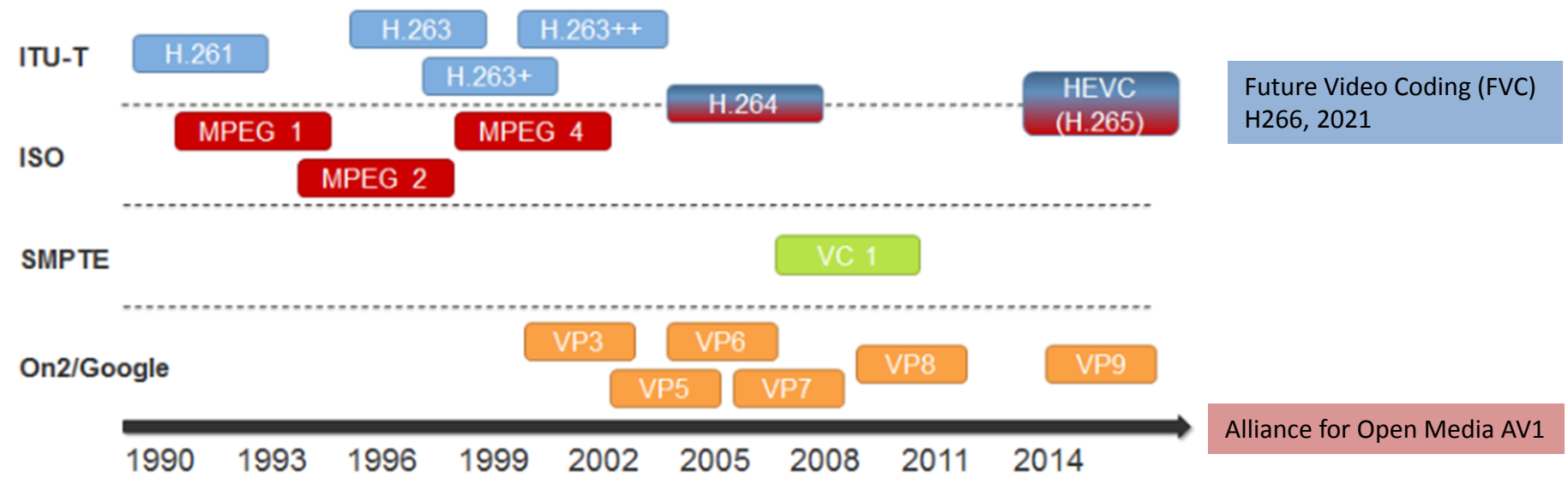

© 2015 Avaya Inc. All rights reserved.

Typical Compression Ratios

Compression Category	Example System	Example Data Rate Ranges	Example Compression Ratios
Uncompressed/Lossless	SDVoE	0.3 – 10 Gbps	1:1 No Compression
Visually Lossless <i>Subjective to judgment of viewer</i>	JPEG2000 MJPEG, DIRAC Pro	30 – 800 Mbps	15:1 to 300:1
Lossy <i>Aggressive to achieve low data rate</i>	MPEG-2, H.264, HEVC	1 – 40 Mbps	300:1 to 3000:1

Codec	Type	Bandwidth	Image quality*	Latency	Technique	Standard
MPEG-2	Lossy	low	low	High	DCT - Inter	Y - royalty
H264/H265	Lossy	low	low	High	Hybrid STPM	Y - royalty
JPEG2000	VL to Lossy	Low to medium	medium	High to Medium	DWT - Intra	Y - royalty
VC2	VL	medium	medium	Medium	DCT - Inter	Y - free
VP9	Lossy	low	low	High	Inter	Y - free
Blue River	VL	high	high	Low	Spatial, line by line	N
DSC	VL	high	high	Low	DPCM+ICH	Y - free

Compression Codecs

Transport and Streaming

- Content streamed or sent to a CDN(Content Delivery Network) and then streamed
 - HLS – HTTP Live Streaming (most popular)
 - HDS – HTTP Dynamic Streaming (based on Adobe Flash)
 - MPEG-DASH – Dynamic Adaptive Streaming over HTTP (the future?)
 - Streaming Techniques
 - ABR – Adaptive Bit Rate Streaming
 - DSS - Dynamic Rate Shaping
 - MBR – MultiBit Rate Streaming

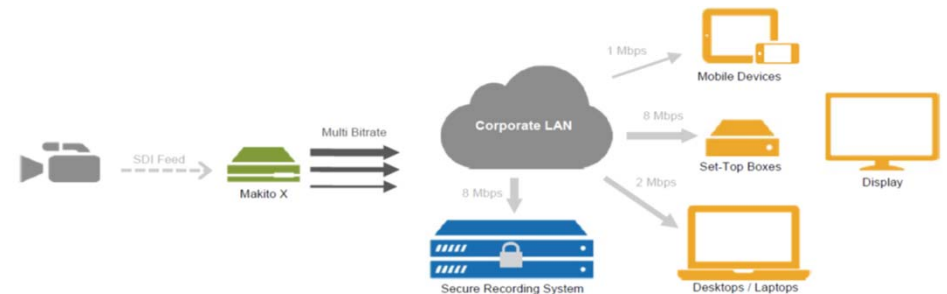
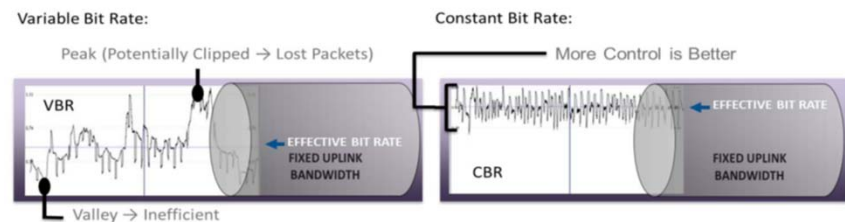

AV-over-IP Quality Comparison

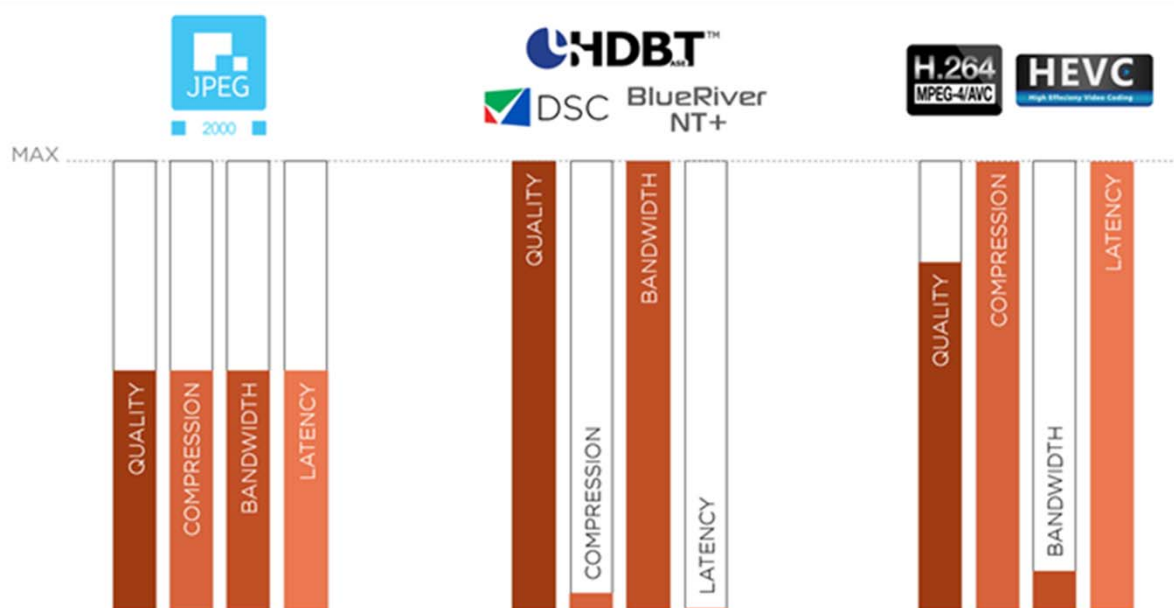

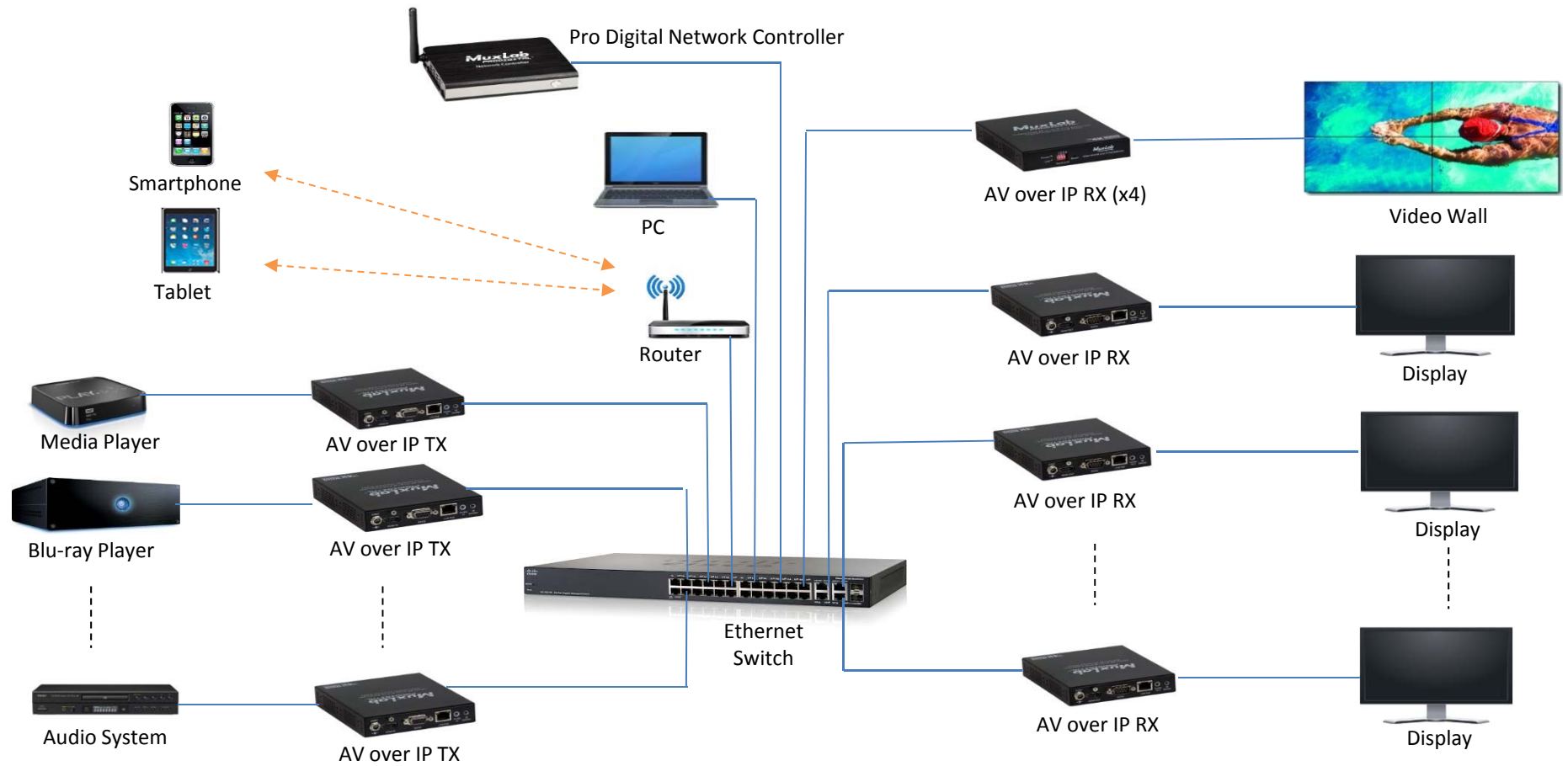

Streaming Application

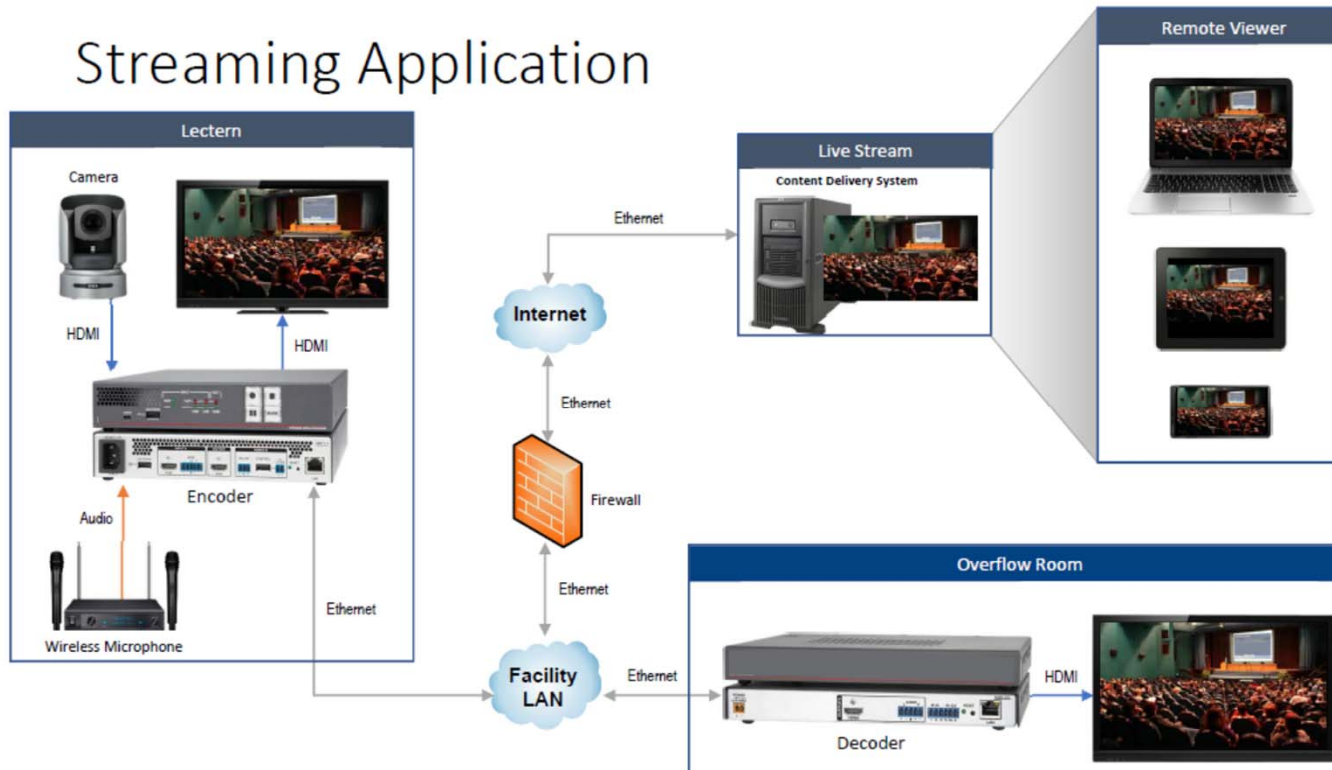

AV over IP – which system should you choose?

- Educate yourself
- Cut through the “noise”
- What does the user need?

It's all about the application!

Thank you for participating.
Are there any questions about
the material we've presented
today?



A Final Thought To Take With You...

**“If it works, it’s obsolete” –
Marshall McLuhan**

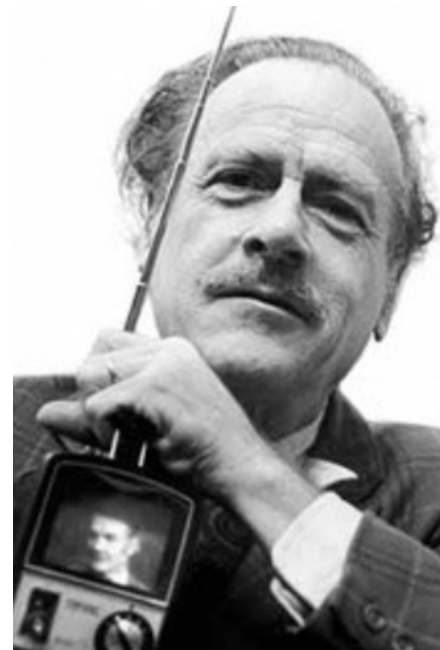

Thank You!

